

2013

THE FEDERAL DEMOCRATIC REPUBLIC OF

ETHIOPIA

ETHIOPIAN ROADS AUTHORITY

**PAVEMENT DESIGN
MANUAL**

**VOLUME II
RIGID PAVEMENTS**

2013



PAVEMENT DESIGN MANUAL VOLUME II: RIGID PAVEMENTS



FOREWORD

The road network in Ethiopia provides the dominant mode of freight and passenger transport and thus plays a vital role in the economy of the country. The network comprises a huge national asset that requires adherence to appropriate standards for design, construction and maintenance in order to provide a high level of service. As the length of the road network is increasing, appropriate choice of methods to preserve this investment becomes increasingly important.

In 2002, the Ethiopian Roads Authority (ERA) first brought out road design manuals to provide a standardized approach for the design, construction and maintenance of roads in the country. Due to technological development and change, these manuals require periodic updating. This current version of the manual has particular reference to the prevailing conditions in Ethiopia and reflects the experience gained through activities within the road sector during the last 10 years. Completion of the review and updating of the manuals was undertaken in close consultation with the federal and regional roads authorities and the stakeholders in the road sector including contracting and consulting industry.

Most importantly, in supporting the preparation of the documents, a series of thematic peer review panels were established that comprised local experts from the public and private sector who provided guidance and review for the project team.

This Manual supersedes the Pavement Design Manual Volume II Rigid Pavements part of the ERA Design Manual series of 2002. The standards set out shall be adhered to unless otherwise directed by ERA. However, I should emphasize that careful consideration to sound engineering practice shall be observed in the use of the manual, and under no circumstances shall the manual waive professional judgment in applied engineering. For simplification in reference this manual may be cited as ERA's *Pavement Design Manual Volume I Rigid Pavements - 2013*.

On behalf of the Ethiopian Roads Authority I would like to take this opportunity to thank DFID, Crown Agents and the AFCAP team for their cooperation, contribution and support in the development of the manual and supporting documents for Ethiopia. I would also like to extend my gratitude and appreciation to all of the industry stakeholders and participants who contributed their time, knowledge and effort during the development of the documents. Special thanks are extended to the members of the various Peer Review Panels whose active support and involvement guided the authors of the manual and the process.

It is my sincere hope that this manual will provide all users with both a standard reference and a ready source of good practice for the pavement design of roads, and will assist in a cost effective operation, and environmentally sustainable development of our road network. I look forward to the practices contained in this manual being quickly adopted into our operations, thereby making a sustainable contribution to the improved infrastructure of our country.

Comments and suggestions on all aspects from any concerned body, group or individual as feedback during its implementation is expected and will be highly appreciated.

Addis Ababa, 2013

Zaid Wolde Gebriel

Director General, Ethiopian Roads Authority

PREFACE

The Ethiopian Roads Authority is the custodian of a series of technical manuals, standard specifications and bidding documents that are written for the practicing engineer in Ethiopia. The series describes current and recommended practice and sets out the national standards for roads and bridges. The manuals are based on national experience and international practice appropriately modified to take account of local experience and local conditions. They are approved by the Director General of the Ethiopian Roads Authority.

Companion documents and manuals include the Standard Technical Specifications, Standard Detailed Drawings and Standard Bidding Documents. The complete series of documents, covering all roads and bridges in Ethiopia, includes:

1. Route Selection Manual
2. Site Investigation Manual
3. Geotechnical Design Manual
4. Geometric Design Manual
5. Pavement Design Manual Volume I Flexible Pavements
6. Pavement Design Manual Volume II Rigid Pavements
7. Pavement Rehabilitation and Asphalt Overlay Design Manual
8. Drainage Design Manual
9. Bridge Design Manual
10. Low Volume Roads Design Manual
11. Standard Environmental Procedures Manual
12. Standard Technical Specifications.
13. Standard Drawings
14. Best Practice Manual for Thin Bituminous Surfacing
15. Standard Bidding Documents for Road Work Contracts – A series of Bidding Documents covering a full range from large scale projects unlimited in value to minor works with an upper threshold of \$300,000. The higher level documents have both Local Competitive Bidding and International Competitive Bidding versions.

These documents are available to registered users through the ERA website: www.era.gov.et

Manual Updates

Significant changes to criteria, procedures or any other relevant issues related to new policies or revised laws of the land or that is mandated by the relevant Federal Government Ministry or Agency should be incorporated into the manual from their date of effectiveness.

Other minor changes that will not significantly affect the whole nature of the manual may be accumulated and made periodically. When changes are made and approved, new page(s) incorporating the revision, together with the revision date, will be issued and inserted into the relevant chapter.

All suggestions to improve the draft manual should be made in accordance with the following procedures:

1. Users of the manual must register on the ERA website: www.era.gov.et
2. Proposed changes should be outlined on the Manual Change Form and forwarded with a covering letter of its need and purpose to the Director General of the Ethiopian Roads Authority.
3. Agreed changes will be approved by the Director General of the Ethiopian Roads Authority on recommendation from the Deputy Director General (Engineering Operations).
4. All changes to the manual will be made prior to release of a new version of the manual.
5. The release date will be notified to all registered users and authorities.

ETHIOPIAN ROADS AUTHORITY CHANGE CONTROL DESIGN MANUAL

MANUAL CHANGE		This area to be completed by the ERA Director of Quality Assurance
Manual Title: _____ _____		CHANGE NO. _____ (SECTION NO. CHANGE NO. _____)
Section Table Figure Page	Explanation	Suggested Modification

Submitted by:

Name: _____ Designation: _____

Company/Organisation Address

_____ email: _____ Date: _____

Manual Change Action

Authority	Date	Signature	Recommended Action	Approval
Registration				
Director Quality Assurance				
Deputy Director General Eng. Ops				

Approval / Provisional Approval / Rejection of Change:

Director General ERA: _____ Date: _____

ACKNOWLEDGEMENTS

The Ethiopian Roads Authority (ERA) wishes to thank the UK Government's Department for International Development (DFID) through the Africa Community Access Programme (AFCAP) for their support in updating this *Pavement Design Manual Volume II Rigid Pavements*. The manual will be used by all authorities and organisations responsible for the provision roads in Ethiopia.

This manual is based on a review of the methods used in several countries but primarily on those used by the UK's Highways Agency based on the research and development work carried out by TRL (Transport Research Laboratory) over many years. Other major reference sources included AASHTO, and, in particular, the AASHTO *Guide for Design of Pavement Structures*, as revised in 1993.

From the outset, the approach to the development of the manual was to include all sectors and stakeholders in Ethiopia. The input from the international team of experts was supplemented by our own extensive local experience and expertise. Local knowledge and experience was shared through a series of meetings of Peer Review Groups comprising specialists drawn from within the local industry which were established to provide advice and comments in their respective areas of expertise. The contribution of the Peer Group participants is gratefully acknowledged

The final review and acceptance of the document was undertaken by an Executive Review Group. Special thanks are given to this group for their assistance in reviewing the final draft of the document.

Finally, ERA would like to thank Crown Agents for their overall management of the project

As with the other manuals of this series, the intent was, where possible, and in the interests of uniformity, to use those tests and specifications included in the AASHTO and/or ASTM Materials references. Where no such reference exists for tests and specifications mentioned in this document, other references are used.

Addis Ababa, 2013

Zaid Wolde Gebriel

Director General, Ethiopian Roads Authority

Executive Review Group		
No.	Name	Organization
1	Alemgena Alene, Dr.	Ethiopian Roads Authority
2	Daniel Nebro, Ato	Ethiopian Roads Authority

List of Persons Contributing to Peer Group Review		
No.	Name	Organization
1	Alemayehu Ayele, Ato	Ethiopian Roads Authority
2	Alemgena Alene, Dr.	Ethiopian Roads Authority
3	Asnake Haile, Ato	OMEGA Consulting Engineers
4	Asrat Sewit, Ato	Saba Engineering
5	Colin Gourley, Dr.	ERA/DFID
6	Daniel Nebro, Ato	Ethiopian Roads Authority
7	Efrem Degefu, Ato	BEACON Consulting Engineers plc
8	Efrem Gebre-Egziabher, Ato	CORE Consulting Engineers
9	Muse Belew, Ato	Ethiopian Roads Authority
10	Shimelis Tesfaye, Ato	Spice Consult
11	Tewodros Alene, Ato	Ethiopian Roads Authority
12	Yohannes Amare, Ato	Private

Project Team			
No.	Name	Organization	Role
1	Bekele Negussie	ERA	AFCAP Coordinator for Ethiopia
2	Abdo Mohammed	ERA	Project Coordinator
3	Daniel Nebro	ERA	Project Coordinator
4	Frew Bekele	ERA	Project Coordinator
5	Rob Geddes	AFCAP/Crown Agents	Technical Manager
6	Les Sampson	AFCAP/Crown Agents	Project Director
7	John Rolt	AFCAP/TRL	Lead Author

TABLE OF CONTENTS

FOREWORD	I
PREFACE	II
ACKNOWLEDGEMENTS	V
TABLE OF CONTENTS	VII
LIST OF ILLUSTRATIONS	IX
LIST OF TABLES	X
GLOSSARY OF TERMS	XI
ABBREVIATIONS	XVII
1 INTRODUCTION	1-1
2 CHARACTERISTICS OF RIGID PAVEMENTS	2-1
2.1 General	2-1
2.2 Types of Rigid Pavements	2-1
2.2.1 <i>Jointed Unreinforced Concrete Pavement</i>	2-2
2.2.2 <i>Jointed Reinforced Concrete Pavement</i>	2-2
2.2.3 <i>Continuously Reinforced Concrete Pavement</i>	2-2
2.3 Pavement Structure	2-2
3 STRESS DEVELOPMENT AND DESIGN CRITERIA	3-1
3.1 Stress Development	3-1
3.1.1 <i>Horizontal Tensile Stresses</i>	3-1
3.1.2 <i>Horizontal Compressive Stresses</i>	3-2
3.1.3 <i>Warping Stresses</i>	3-2
3.1.4 <i>Shear and Bending Stresses</i>	3-3
3.2 Design Criteria	3-4
4 JOINTS	4-1
4.1 Transverse Joints	4-1
4.1.1 <i>Contraction Joints</i>	4-1
4.1.2 <i>Expansion Joints</i>	4-1
4.1.3 <i>Warping Joints</i>	4-2
4.2 Longitudinal Joints	4-2
4.3 Construction Joints	4-3
5 SELECTION OF PAVEMENT TYPE	5-1
6 DESIGNING RIGID PAVEMENTS	6-1
6.1 Design Life	6-1
6.2 Design Traffic Loading	6-1
6.3 Thickness Design.....	6-4
6.3.1 <i>Capping and Sub-base</i>	6-4
6.3.2 <i>Concrete Slab Thickness and Reinforcement</i>	6-5

6.4	Design for Movement.....	6-13
6.4.1	<i>Transverse Joint Spacing</i>	6-14
6.4.2	<i>Longitudinal Joint Spacing</i>	6-14
6.5	Design Detailing.....	6-14
6.5.1	<i>Bay-layout</i>	6-14
6.5.2	<i>Gullies and Man-holes</i>	6-15
6.5.3	<i>Integral Curbs</i>	6-15
6.5.4	<i>End Anchorage for Continuously Reinforced Pavement Slabs</i>	6-16
7	REFERENCES	7-1
	APPENDIX A: SUB-BASE AND CAPPING LAYER REQUIREMENTS	A-1
	APPENDIX B: RIGID PAVEMENT DESIGN - DESIGN EXAMPLE	B-1
	APPENDIX C: TYPICAL DETAILS	C-1

LIST OF ILLUSTRATIONS

Figure 1-1: Jointed unreinforced concrete road with a tied concrete shoulder Design Standard DC7, Traffic Class T8.....	1-2
Figure 1-2: Jointed unreinforced concrete road in a semi-rural area with a shoulder of unbound material: Design Standard DC6, Traffic Class T6	1-3
Figure 1-3: Low volume jointed unreinforced concrete road in a rural area- Design Standard DC5, Traffic Class T2.....	1-3
Figure 2-1: Tie bars in place to connect to parallel concrete slab	2-2
Figure 2-2: Rigid Pavement structure.....	2-3
Figure 3-1: Curling of concrete slab due to moisture gradients	3-3
Figure 3-2: Curling of concrete slab due to temperature gradients	3-3
Figure 4-1: Transverse construction joint for CRCP slabs.....	4-3
Figure 6-1: Design Process Flow Diagram	6-3
Figure 6-2: Design Thicknesses for JUCP with and without tied shoulders.....	6-6
Figure 6-3: Design Thicknesses for JRCP with tied shoulders	6-9
Figure 6-4: Design Thicknesses for JRCP concrete without tied shoulders.....	6-12
Figure 6-5: Design Thickness for CRCP with tied shoulders	6-13
Figure 6-6: Additional Concrete Thickness for CRCP when there is no full lateral support provided by tied shoulders	6-13
Figure 6-7: Joints layout at junctions and crossings.....	6-14
Figure 6-8: Box-out around in-pavement objects – layout of joints.....	6-15
Figure 6-9: Typical Integral Curb.....	6-15

LIST OF TABLES

Table 6-1: Equivalency Factors for Rigid Pavements..... 6-2
Table 6-2: Thickness of Sub-base and Capping Layers..... 6-4
Table 6-3: Additional Thickness for JUCP with Unstabilised Sub-bases (mm)..... 6-5
Table 6-4: Additional Thickness for JRCP with Unstabilised Sub-bases (mm)..... 6-5

GLOSSARY OF TERMS

Aggregate	Hard mineral elements of construction material mixtures, for example: sand, gravel (crushed or uncrushed) or crushed rock.
Asphalt	In American literature asphalt is another term for bitumen. The term is also commonly used in this way in Ethiopia. In other countries, asphalt is commonly used as shorthand for asphaltic concrete or, indeed, any design of high quality bitumen/aggregate mixture.
Asphalt Concrete	A mixture to predetermined proportions of aggregate, filler and bituminous binder material plant mixed and usually placed by means of a paving machine.
Asphalt Surfacing	The layer or layers of asphalt concrete constructed on top of the roadbase, and, in some cases, the shoulders.
Average Annual Daily Traffic (AADT)	The total yearly traffic volume in both directions divided by the number of days in the year.
Average Daily Traffic (ADT)	The total traffic volume during a given time period in whole days greater than one day and less than one year divided by the number of days in that time period.
Base Course	This is the main component of the pavement contributing to the spreading of the traffic loads. In many cases, it will consist of crushed stone or gravel, or of good quality gravelly soils or decomposed rock. Bituminous base courses may also be used (for higher classes of traffic). Materials stabilised with cement or lime may also be contemplated.
Binder Course	The lower course of an asphalt surfacing laid in more than one course.
Bitumen	The most common form of bitumen is the residue from the refining of crude oil after the more volatile material has been distilled off. It is a very viscous liquid comprising many long-chain organic molecules. For use in roads it is practically solid at ambient temperatures but can be heated sufficiently to be poured and sprayed. Some natural bitumens can be found worldwide that are not distilled from crude oil but the amounts are very small.
Borrow Area	An area within designated boundaries, approved for the purpose of obtaining borrow material. A borrow pit is the excavated pit in a borrow area.
Borrow Material	Any gravel, sand, soil, rock or ash obtained from borrow areas, dumps or sources other than cut within the road prism and which is used in the construction of the specified work for a project. Not including crushed stone or sand obtained from commercial sources.

Boulder	A rock fragment, usually rounded by weathering or abrasion, with an average dimension of 0.30 m or more.
Bound Pavement Materials	Pavement materials held together by an adhesive bond between the materials and a binding material such as bitumen.
Camber	The convexity given to the curved cross-section of a roadway.
Capping Layer	(Selected or improved subgrade). The top of embankment or bottom of excavation prior to construction of the pavement structure. Where very weak soils and/or expansive soils (such as black cotton soils) are encountered, a capping layer is sometimes necessary. This consists of better quality subgrade material imported from elsewhere or subgrade material improved by stabilisation (usually mechanical), and may also be considered as a lower quality sub-base.
Carriageway	That portion of the roadway including the various traffic lanes and auxiliary lanes but excluding shoulders.
Contraction Joint	A joint normally placed at recurrent intervals in a rigid slab to control transverse cracking.
Cross-Section	A vertical section showing the elevation of the existing ground, ground data and recommended works, usually at right angles to the centerline.
Crossfall	The difference in level measured transversely across the surface of the roadway.
Culvert	A structure, other than a bridge, which provides an opening under the carriageway or median for drainage or other purposes.
Cutting	Cutting shall mean all excavations from the road prism including side drains, and excavations for intersecting roads including, where classified as cut, excavations for open drains.
Chippings	Stones used for surface dressing (treatment).
Deformed Bar	A reinforcing bar for rigid slabs conforming to “Requirements for Deformations” in AASHTO Designations M 31M.
Design Period	The period of time that an initially constructed or rehabilitated pavement structure will perform before reaching a level of deterioration requiring more than routine or periodic maintenance.
Diverted Traffic	Traffic that changes from another route (or mode of transport) to the project road because of the improved pavement, but still travels between the same origin and destination.
Dowel	A load transfer device in a rigid slab, usually consisting of a plain round steel bar. Unlike a tie bar, a dowel may permit horizontal movement.

Equivalent Standard Axles (ESAs)	A measure of the potential damage to a pavement caused by a vehicle axle load expressed as the number of 8.16 metric tonne single axle loads that would cause the same amount of damage. The ESA values of all the traffic are combined to determine the total design traffic for the design period.
Equivalency Factors	Used to convert traffic volumes into cumulative equivalent standard axle loads.
Equivalent Single Axle Load (ESA)	Summation of equivalent 8.16 ton single axle loads used to combine mixed traffic to calculate the design traffic loading for the design period.
Escarpment	Escarpsments are geological features that are very steep and extend laterally for considerable distances, making it difficult or impossible to construct a road to avoid them. They are characterised by more than 50 five-metre contours per km and the transverse ground slopes perpendicular to the ground contours are generally greater than 50%.
Expansion Joint	A joint located to provide for expansion of a rigid concrete slab without damage to itself, adjacent slabs, or structures.
Fill	Material of which a man-made raised structure or deposit such as an embankment is composed, including soil, soil-aggregate or rock. Material imported to replace unsuitable roadbed material is also classified as fill.
Flexible Pavements	Includes primarily those pavements that have a bituminous (surface dressing or asphalt concrete) surface. The terms "flexible and rigid" are somewhat arbitrary and were primarily established to differentiate between asphalt and Portland cement concrete pavements.
Formation Level	Level at top of subgrade.
Generated Traffic	Additional traffic which occurs in response to the provision of improvement of the road.
Grading Modulus (GM)	Related to the cumulative percentages by mass of material in a representative sample of aggregate, gravel or soil retained on the 2.36 mm, 0.425 mm and 0.075 mm sieves; $GM = 3 - \left(\frac{P_{2.36} + P_{0.425} + P_{0.075}}{100} \right)$ where: $P_{2.36}$ = percentage passing 2.36 mm sieve $P_{0.425}$ = percentage passing 0.425 mm sieve $P_{0.075}$ = percentage passing 0.075 mm sieve
Heavy Vehicles	Those having an unloaded weight of 3,000 kg or more.

Hot mix asphalt (HMA)	This is a generic name for all high quality mixtures of aggregates and bitumen that use the grades of bitumen that must be heated in order to flow sufficiently to coat the aggregates. It includes Asphaltic Concrete, Dense Bitumen Macadam and Hot Rolled Asphalt.
Longitudinal Joint	A joint normally placed between traffic lanes in rigid pavements to control longitudinal cracking.
Maintenance	Routine work performed to keep a pavement as nearly as possible in its as-constructed condition under normal conditions of traffic and forces of nature.
Mountainous (Terrain)	Terrain that is rugged and very hilly with substantial restrictions in both horizontal and vertical alignment. It is defined as having 26-50 five-metre contours per km. The transverse ground slopes perpendicular to the ground contours are generally above 25%.
Normal Traffic	Traffic which would pass along the existing road or track even if no new pavement were provided.
Overlay	One or more courses of asphalt construction on an existing pavement. The overlay often includes a levelling course, to correct the contour of the old pavement, followed by a uniform course or courses to provide needed thickness.
Pavement Layers	The layers of different materials which comprise the pavement structure.
Project Specifications	The specifications relating to a specific project, which form part of the contract documents for such project, and which contain supplementary and/or amending specifications to the standard specifications.
Pumping	The ejection of foundation material, either wet or dry, through joints or cracks, or along edges of rigid slabs resulting from vertical movements of the slab under traffic.
Quarry	An area within designated boundaries, approved for the purpose of obtaining rock by sawing or blasting.
Reconstruction	The process by which a new pavement is constructed, utilizing mostly new materials, to replace an existing pavement.
Recycling	The reuse, usually after some processing, of a material that has already served its first-intended purpose.
Rehabilitation	Work undertaken to significantly extend the service life of an existing pavement. This may include overlays and pre overlay repairs, and may include complete removal and reconstruction of the existing pavement, or recycling of part of the existing materials.
Reinforcement	Steel embedded in a rigid slab to resist tensile stresses and detrimental opening of cracks.

Rigid Pavement	A pavement structure which distributes loads to the subgrade having, as the main load bearing course, a Portland cement concrete slab of relatively high-bending resistance.
Roadbase	A layer of material of defined thickness and width constructed on top of the sub-base, or in the absence thereof, the subgrade. A roadbase may extend to outside the carriageway.
Road Bed	The natural in situ material on which the fill, or in the absence of fill, any pavement layers, are to be constructed.
Road Bed Material	The material below the subgrade extending to such depth as affects the support of the pavement structure.
Road Prism	That portion of the road construction included between the original ground level and the outer lines of the slopes of cuts, fills, side fills and side drains. It does not include sub-base, roadbase, surfacing, shoulders, or existing original ground.
Roadway	The area normally travelled by vehicles and consisting of one or a number of contiguous traffic lanes, including auxiliary lanes and shoulders.
Rolling (Terrain)	Terrain with low hills introducing moderate levels of rise and fall with some restrictions on vertical alignment. Defined as terrain with 11-25 five-metre contours per km. The transverse ground slopes perpendicular to the ground contours are generally between 3 and 25%.
Side Fill	That portion of the imported material within the road prism which lies outside the fills, shoulders, roadbase and sub-base and is contained within such surface slopes as shown on the Drawings or as directed by the Engineer. A distinction between fills and side fill is only to be made if specified.
Side Drain	Open longitudinal drain situated adjacent to and at the bottom of cut or fill slopes.
Stabilisation	The treatment of the materials used in the construction of the road bed material, fill or pavement layers by the addition of a cementitious binder such as lime or Portland Cement or the mechanical modification of the material through the addition of a soil binder or a bituminous binder. Concrete and asphalt shall not be considered as materials that have been stabilised.
Sub-base	The layer of material of specified dimensions on top of the subgrade and below the roadbase. The secondary load-spreading layer underlying the base course. Usually consisting of a material of lower quality than that used in the base course and particularly of lower bearing strength. Materials may be unprocessed natural gravel, gravel-sand, or gravel-sand-clay, with controlled gradation and plasticity characteristics. The sub-base also serves as a separating

	layer preventing contamination of the base course by the subgrade material and may play a role in the internal drainage of the pavement.
Subgrade	The surface upon which the pavement structure and shoulders are constructed. The top portion of the natural soil, either undisturbed (but recompacted) local material in cut sections, or soil excavated in cut or borrow areas and placed as compacted embankment.
Subsurface Drain	Covered drain constructed to intercept and remove subsoil water, including any pipes and permeable material in the drains.
Surface Treatment	The sealing or resealing of the carriageway or shoulders by means of one or more successive applications of bituminous binder and crushed stone chippings.
Surfacing	The top layer(s) of the flexible pavement consisting of a bituminous surface dressing or one or two layers of premixed bituminous material (generally asphalt concrete). Where premixed materials are laid in two layers, these are known as the wearing course and the binder course.
Tie Bar	A deformed steel bar or connector embedded across a joint in a rigid concrete slab to prevent separation of abutting slabs. (Not to be confused with Dowels.)
Traffic Lane	Part of a travelled way intended for a single stream of traffic in one direction, which has normally been demarcated as such by road markings.
Traffic Volume	Volume of traffic usually expressed in terms of average annual daily traffic (AADT).
Typical Cross-Section	A cross-section of a road showing standard dimensional details and features of construction.
Unbound Pavement Materials	Naturally occurring or processed granular material which is not held together by the addition of a binder such as cement, lime or bitumen.
Wearing Course	The top course of an asphalt surfacing or, for gravel roads, the uppermost layer of construction of the roadway made of specified materials.
Welded Wire Fabric	Welded steel wire fabric for concrete reinforcement.

ABBREVIATIONS

AADT	Average Annual Daily Traffic
AASHO	American Association of State Highway Officials (previous designation)
AASHTO	American Association of State Highway and Transportation Officials
AC	Asphalt Concrete
ACV	Aggregate Crushing Value – a measure of aggregate strength
ASTM	American Society for Testing Materials
BS	British Standard
CBR	California Bearing Ratio (as described in AASHTO T 193)
CRCP	Continuously Reinforced Concrete Pavement
DCP	Dynamic Cone Penetrometer
m_2, m_3	Drainage coefficients. Factors used to modify <i>layer coefficients</i> in flexible pavements to take account of climate, the effectiveness of internal pavement drainage and moisture sensitivity.
ERA	Ethiopian Road Authority
ESA	Equivalent standard axles. A measure of the damaging effect of vehicle axles (<i>see ERA Pavement Design Manual Volume I</i>)
FWD	Falling Weight Deflectometer
GM	Grading Modulus
HMA	Hot Mixed Asphalt
ICL	Initial Consumption of Lime test
IRI	International Roughness Index
LAA	Los Angeles Abrasion Value – a measure of aggregate strength
MDD	Maximum Dry Density
NDT	Non destructive test
JPCP	Jointed Plain Concrete Pavement
JRCP	Jointed Reinforced Concrete Pavement
a_1, a_2, a_3	Strength coefficients. The empirical strength coefficients used for weighting the contribution of each layer of the pavement to

	the overall structural number (SN). They are modified by the drainage coefficients (see above).
NDT	Non destructive testing
PCC	Portland Cement concrete
PMS	Pavement management system
RRD	Representative rebound deflection
S1 to S6	Subgrade strength classes used to characterize the subgrade in pavement design (see <i>ERA Pavement Design Manual Volume I</i>)
SN and MSN	Structural Number and Modified Structural Number. An index of overall pavement strength based on the thicknesses and strengths of each pavement layer.
SN _{eff} and MSN _{eff}	Effective Structural Number of an existing pavement
T1 to T11	Traffic classes used to characterize the anticipated traffic in terms of ESA for pavement design purposes
h ₁ , h ₂ , h ₃	Thicknesses of pavement surface, base and sub-base layers (existing or required)
TRL	Transport Research Laboratory, UK (formerly TRRL)
TRRL	Transport and Road Research Laboratory, UK
VOC	Vehicle Operating Costs
VFB	Voids Filled with Bitumen
VIM	Voids in the Mix
VMA	Voids in the Mineral Aggregate

1 INTRODUCTION

The purpose of this *Pavement Design Manual Volume II Rigid Pavements* is to give specific guidance and recommendations to the engineers responsible for the design of rigid pavements in Ethiopia.

This volume contains:

- i) A description of the types of rigid pavements, their characteristics, their components and their function, the different types of slabs and joints, and includes drawing details.
- ii) A description of the factors influencing the selection of the pavement type and the design process.
- iii) A design procedure for the different types of pavement, slab reinforcement, joint details and joint layout.

Rigid pavements have often been considered only for heavily trafficked roads because of their initial high cost and their excellent traffic carrying capacity. As a result, the major portion of the paved road network in most countries consists of flexible pavements. However several countries have adopted rigid pavements more widely. This is because they last a long time and their maintenance demands are low so that, in whole life cost terms, they can provide good value for money. Naturally this depends on the relative costs of the materials, but rigid pavements have a role to play across the entire traffic spectrum and, on low volume roads, can be used to advantage in difficult situations where other types of road pavement may not be durable and sustainable (Figure 1.1, 1.2 and 1.3).

This manual is concerned only with aspects of pavement design that are *specific* to rigid pavements. Aspects that are common to both rigid and flexible pavements are dealt with in ERA's *Pavement Design Manual Volume I Flexible Pavements*. This includes:

- i) Traffic assessment and forecasting.
- ii) Evaluating subgrade strength.
- iii) Drainage and shoulders.
- iv) Unbound materials for capping layers and sub-bases.
- v) Cement and lime-stabilisation for sub-bases.
- vi) Earthworks.

The design method is based primarily on empirical data from full scale experiments carried out by TRL in the UK (Mayhew and Harding, 1987). The method produces thickness designs that are generally similar to those obtained using the design method developed in the USA from empirical data obtained during the AASHO Road Test. However, the UK data extends to over 30 million equivalent standard axles, which is considerably more than the traffic on the AASHO Road Test and hence the method should be more reliable at the higher traffic levels.

In addition, the AASHTO method requires a number of assumptions and choices of several input parameters that designers will not be able to determine. In practice, users have generally adopted the default values of these parameters discussed in the AASHTO manual

but, by adopting different values, quite large changes in design thicknesses can be obtained.

Because of the nature of the deterioration of rigid pavements, defining the terminal condition is not as straightforward as it is for flexible pavements. In the UK a reliability of only 50% was used in the data analysis and in the main published design charts. This may seem rather low for principal roads, but the definition of terminal condition is relatively conservative. In this manual a reliability of 85% is used for added safety in view of the lower quality of concrete that is achievable in local practice and to cover uncertainties in the design models at these lower strengths.

Both the UK and AASHTO methods have been used successfully for many years for designing roads carrying high levels of traffic. However, it should be born in mind that designs for high traffic levels are an extrapolation of the experimental data. Although the experimental data have been used to calibrate theoretical approaches to help to extend the designs to higher levels of traffic as reliably as possible, the use of extrapolated data should be considered somewhat experimental.

It is noted that the extrapolation of design charts to high levels of traffic for flexible pavements has been shown to produce very conservative designs and, in many countries, the newer design thicknesses are no longer based on extrapolation (See ERA's *Pavement Design Manual Volume I Flexible Pavements*). Rigid pavements are normally designed for 40 years and therefore direct evidence for such long term performance is not abundant, hence there is more uncertainty about long term behaviour.

Although theoretical methods are also available based on calculations of the stresses and strains induced in the pavement by an applied wheel load and environmental effects, the methods are tedious, rarely used, and lead to only marginal changes in the designs. In view of the tolerances required when constructing pavement layers, these small variations are of little consequence and therefore such methods are not presented in this manual.



**Figure 1-1: Jointed unreinforced concrete road with a tied concrete shoulder
Design Standard DC7, Traffic Class T8**



Figure 1-2: Jointed unreinforced concrete road in a semi-rural area with a shoulder of unbound material: Design Standard DC6, Traffic Class T6



Figure 1-3: Low volume jointed unreinforced concrete road in a rural area- Design Standard DC5, Traffic Class T2

2 CHARACTERISTICS OF RIGID PAVEMENTS

2.1 General

Rigid pavements (also called concrete pavements) usually comprise two or three layers; a capping layer if the subgrade is weak, a sub-base layer and a strong, stiff concrete layer. The specifications for the capping layer and sub-base and methods of determining the strength of the subgrade for design purposes are essentially the same as for flexible pavements. For convenience the specifications are shown in Appendix A.

As the name ‘rigid’ implies, the deflections under a loaded wheel are very small compared with the deflections observed in flexible pavements and the stresses within the underlying sub-base and subgrade are also comparatively small. Rigid pavements therefore deteriorate through quite different mechanisms from those that affect flexible pavements.

Rigid pavements have the following advantages:

- i) It is feasible to design rigid pavements for very long design lives, up to 60 years and deterioration is usually very slow.
- ii) Little maintenance is generally required.
- iii) Rigid pavements do not deform under traffic.
- iv) A relatively thin pavement slab distributes the load over a wide area due to its high rigidity.
- v) Concrete is very resistant to abrasion making the anti-skidding surface texture last longer.
- vi) In the absence of deleterious materials (either in the aggregate or entering the concrete in solution from an external source) and unlike flexible pavements, concrete does not suffer significant deterioration from weathering. Neither its strength nor its stiffness is significantly affected by temperature changes.

The main disadvantage compared to a flexible pavement is that if a rigid pavement is not properly constructed it tends to be more troublesome and reconstruction or repair can be more difficult.

The initial cost of a rigid pavement is often considered a disadvantage but, depending on the relative costs of materials, their whole life costs can be considerably less than flexible pavements and they can therefore provide a more sustainable option.

Concrete pavements have not been used extensively in most tropical countries including Ethiopia. This is mainly due to a lack of tradition and experience in their design and construction. However several tropical countries have invested heavily and successfully in rigid pavements (e.g. Philippines and Chile) and their use is widespread in Europe and the USA. There appears to be no technical reason why more use should not be made of them in Ethiopia.

2.2 Types of Rigid Pavements

There are three basic types of rigid pavement:

- i) Jointed Unreinforced Concrete Pavements (JUCP)

- ii) Jointed Reinforced Concrete Pavements (JRCP)
- iii) Continuously Reinforced Concrete Pavements (CRCP)

2.2.1 Jointed Unreinforced Concrete Pavement

In Jointed Unreinforced Concrete Pavements (JUCP) the pavement consists of unreinforced concrete slabs cast in place and divided into bays of predetermined dimensions by the construction of joints. The dimensions of the bays are made sufficiently short to ensure that they do not crack through shrinkage during the concrete curing process. In the longitudinal direction the bays are usually linked together by dowels to prevent vertical movement and to help maintain aggregate interlock across the transverse joints. The bays are also connected to parallel slabs by tie bars, the main function of which is to prevent horizontal movement (i.e. the opening of warping joints) Figure 2.1.



Figure 2-1: Tie bars in place to connect to parallel concrete slab

2.2.2 Jointed Reinforced Concrete Pavement

In Jointed Reinforced Concrete Pavements (JRCP) the pavement consists of cast in place concrete slabs containing steel reinforcement and divided into bays separated by joints. The reinforcement is to prevent cracks from opening and this allows much longer bays to be used than for JUCP. The bays are linked together by dowels and tie bars as in JUCP. Although longitudinal reinforcement is the main reinforcement, transverse reinforcement is also used in most cases to facilitate the placing of longitudinal bars.

2.2.3 Continuously Reinforced Concrete Pavement

Continuously Reinforced Concrete Pavements (CRCP) are made of cast in place reinforced concrete slabs without joints. The expansion and contraction movements are prevented by a high level of sub-base restraint. The frequent transverse cracks are held tightly closed by a large amount of continuous high tensile steel longitudinal reinforcement.

2.3 Pavement Structure

Rigid pavements usually consist of a sub-base and a concrete slab but a capping layer is also used if required (Figure 2.2). When the subgrade is weak, the required thickness of material of sub-base quality required to protect the subgrade and to provide sufficient

support for the concrete slab is substantial and it is usually more economical to provide a capping layer to perform part of the task, as shown in the Figure.

Any erosion of the sub-base layer under the concrete slab caused by the pumping action as traffic uses the road reduces the support to the concrete slab. This increases the tensile strains in the concrete itself and therefore the risk of cracking. In circumstances where this is likely it is recommended that the sub-base material is stabilised with cement or lime to provide support that is strongly resistant to erosion.

The sub-base is also required to provide a stable working platform on which to construct the concrete slab

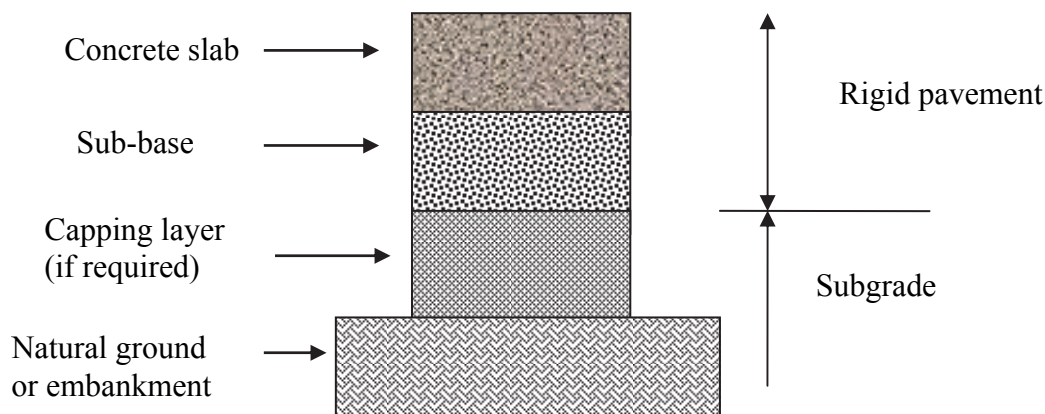

Figure 2-2: Rigid Pavement structure

If the quality of the subgrade is acceptable, and if the design traffic is low (less than one million ESAs) a sub-base layer may not be strictly necessary between the prepared subgrade and the concrete slab. However, a sub-base layer makes it easier to achieve the required elevations within the specified tolerances and is usually recommended.

The concrete slab itself consists of Portland cement concrete, reinforcing steel (when required), load transfer devices and joint sealing materials.

For reinforced concrete pavements, transverse reinforcement is also provided to ensure that the longitudinal bars remain in the correct position during the construction of the slab. It also helps to control any longitudinal cracking that may develop.

The details of pavement layer thicknesses and the amount of reinforcement required are discussed in Chapter 6.

3 STRESS DEVELOPMENT AND DESIGN CRITERIA

3.1 Stress Development

The concrete slabs in concrete pavements are subjected to two main types of stresses:

- i) The stresses developed because of changes of the environment (moisture and temperature). These are related to the intrinsic properties of the concrete. In Ethiopia, although the annual range of temperature is small the daily range of temperature is high, varying from 20°C to 40°C. Therefore thermal stresses deserve special attention.
- ii) The stresses generated by the traffic.

The design of concrete pavements must take both types of stresses into account in order to keep them within acceptable ranges of values. Analytical methods have been developed for computing the stresses in concrete pavements but the response of the pavement to these stresses is less predictable and requires assumptions that are not sufficiently robust. For this reason empirical design methods are favoured by most authorities. Nevertheless, an appreciation of the engineering environment and performance mechanisms of rigid pavements is important for justifying the pragmatic design procedure described in Chapter 6 of this manual.

3.1.1 Horizontal Tensile Stresses

During the curing process, the moisture content of the concrete decreases. Later in the life of the pavement the moisture content can also change as a result of climatic factors (humidity). Decreasing moisture content is a shrinking process and therefore tensile stresses in the concrete are developed.

Tensile stresses are also developed when the temperature of the concrete slab decreases, the magnitude of which depends upon the coefficient of thermal expansion of the concrete.

Finally the passage of the wheel of a heavy truck deflects the concrete slab vertically and induces a dynamic tensile stress at the lower surface.

Since movement of the lower face of the concrete slab is also constrained by the friction between the slab and the sub-base, the horizontal stresses cannot be readily dissipated. If the total tensile stress exceeds the tensile strength of the concrete, cracks will develop in the slabs.

When cracks become wide, they enable the ingress of water and, depending on the materials making up the pavement layers, may result in weakening of the foundations of the concrete slabs and accelerated deterioration.

If water is present and the load transfer across transverse joints is poor (so that the vertical movement of one slab is different to that of its neighbour), and the sub-base material is erodible, the regular pumping action caused by traffic can be particularly serious. Voids can be easily created under the slab leading to lack of support for the slab and the generation of even higher stresses and accelerated deterioration.

Depending on the type of slab these mechanisms are dealt with differently:

JUCP

The development of cracks is controlled by constructing joints at regular intervals and, sometimes, by including a separation membrane between the slab and the sub-base. The relatively short length of the bays and the increased possibility of horizontal movements limit the tensile stresses and thereby prevent the slabs from cracking between joints.

JRCP

The transverse cracks which are expected to develop between transverse joints are held tightly closed by the longitudinal reinforcement that is incorporated into the slab.

CRCP

The continuous reinforcement causes the cracking to occur at regular and short-spaced locations. This limits the opening of cracks to acceptable values.

3.1.2 Horizontal Compressive Stresses

If the temperature rises, thermal compressive stresses are induced. Their magnitude depends on the thermal coefficient of the concrete. If they become too high, this may cause the slab to buckle.

According to the type of slab, this issue is treated as follows:

JUCP and JRCP

The placing of expansion joints and the increased possibility of movement through the use of the separation membrane permit the expansion of the concrete and the dissipation of compressive stresses. Nevertheless, the issue can be avoided as far as possible by casting the concrete at the hottest period of the year. The natural contraction as the slabs cool down ensures that there is sufficient space for expansion during the next hot period.

CRCP

The continuous reinforcement increases the resistance of slabs to compressive failures but the compressive stresses can be very high. CRCP is the option most prone to expansion failure because of the great length of slab between joints. It is thus preferable to cast CRCP slabs during the hottest time of the year so that the natural contraction during cooling leaves sufficient space for expansion during the next hot season.

3.1.3 Warping Stresses

Warping stresses occur in rigid pavement slabs when variations in moisture content and/or temperature from the top to the bottom of the slab occur.

In dry climates, or dry periods, the top of the slab is drier than the bottom, causing the edges of the slab to curl upwards as illustrated in Figure 3.1. This induces tensile stresses at the top of the slab and compressive stresses at the bottom. The stresses are increased considerably when heavy vehicles pass along the road.

Permanent warping stresses also occur because the top of the slab cures faster and shrinks more than the bottom.

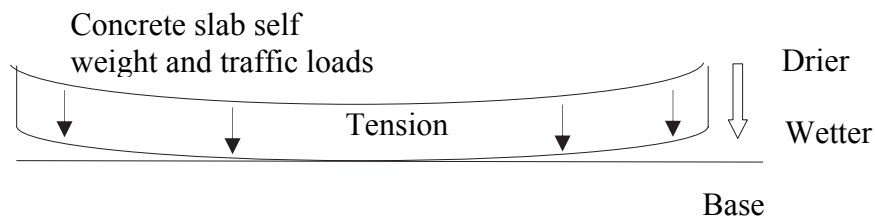

Figure 3-1: Curling of concrete slab due to moisture gradients

During daytime, the top of the slab tends to be warmer than the bottom, causing the *middle* of the slab to heave and inducing tensile stresses at the bottom of the slab and compressive stresses at its top as illustrated in Figure 3.2. During the night, the opposite phenomenon occurs and the slab curls in the opposite direction.

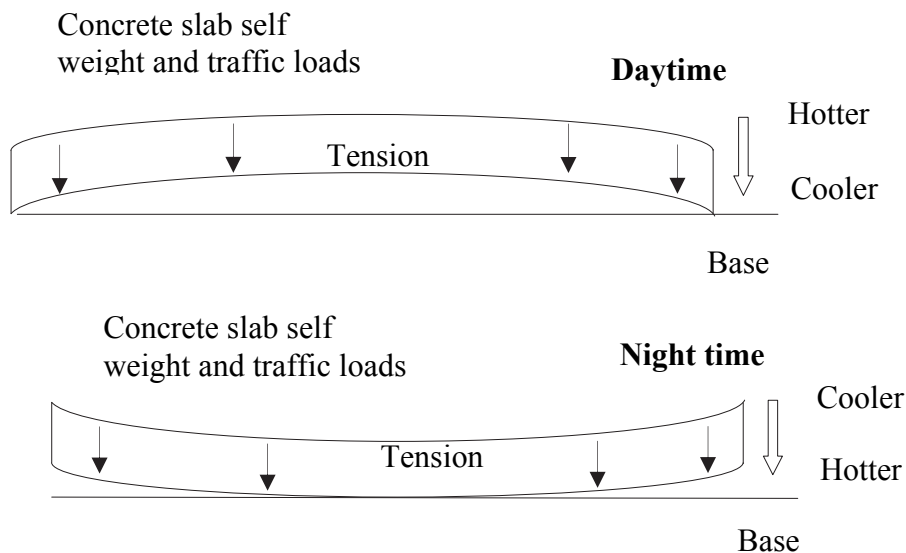

Figure 3-2: Curling of concrete slab due to temperature gradients

Warping stresses are limited by providing joints, either warping or contraction joints, which allow a slight relative rotation of the bays.

3.1.4 Shear and Bending Stresses

With a minimum concrete thickness of 150 mm and *continuous support* from the sub-base, the shear and bending stresses developed by the traffic loads are not usually large enough to cause the concrete slabs to crack and a fatigue law similar to that for flexible pavements is used to estimate the damage caused by traffic (Section 6.2).

However, significant loss of support to the slab over an extended area through movements of the sub-base or of the subgrade dramatically increases the probability of cracking. The continuous transmission of vertical loads along the pavement is essential because relative vertical movements of the bays create pumping mechanisms which accelerate the loss of support and hence the deterioration of the road.

3.2 Design Criteria

The factors which control the performance of a rigid pavement and for which design criteria are required are as follows:

- i) Quality of the concrete and steel for constructing the pavement slabs.
- ii) Strength of the subgrade.
- iii) Quality of the sub-base.
- iv) Environment (moisture and temperature).
- v) Traffic and design life.

For the design procedure recommended in this manual, the assumptions are made that the materials used for construction meet the following requirements:

1. 28-day characteristic compressive strength of 30, 35 or 40 MPa for the concrete.
2. Yield strength of the steel reinforcement bars is greater than 400 MPa.

The required properties of sub-base and capping layer are as defined in ERA's *Pavement Design Manual Volume I: Flexible Pavements*. These are shown in Appendix A for convenience.

The assessment of subgrade strength for design and the estimation of design traffic is also as described in *Volume I* except that the relationship between pavement damage and axle load is slightly different for rigid pavements, as described in Chapter 6.

The principal difference between a rigid pavement and a flexible pavement is the need for 'joints' and these are discussed in the next chapter.

4 JOINTS

Joints are placed in concrete pavements to permit expansion, contraction and warping of the slab, thereby relieving stresses due to environmental changes (temperature and moisture) and to facilitate construction. Joints are classified according to their direction, either transverse or longitudinal, and their function. They are basically called contraction, expansion, warping or construction joints but in most cases they combine several of these functions.

Typical details of the different types of joints are presented in Appendix B.

4.1 Transverse Joints

Transverse Joints are the joints perpendicular to the centre-line of the road. They are designed to prevent contraction and expansion stresses which develop over long distances. In some specific places such as around in-pavement objects or at junctions, transverse joints are also required to limit warping stresses.

4.1.1 Contraction Joints

Contraction joints are the principal type of transverse joints. They are required in both JRCP and JUCP to relieve the tensile stresses caused by temperature or moisture changes. They are formed by providing a thin, weakened strip at preferred locations in the concrete (between bays) so that a transverse crack forms at that point as a result of the tension in the slab. If contraction joints were not installed, random and uncontrolled cracking would occur in the slab. They also contribute to the limitation of the warping stresses.

Load transfer between bays is provided by dowels.

Contraction joints consist of:

- i) A sawn joint groove.
- ii) Dowel bars.
- iii) A sealing groove.

The groove and sealant must be as specified. The dowel bars should be at 300 mm spacing and 400 mm long. They should be:

- i) 20 mm in diameter for slabs up to 239 mm thick.
- ii) 25 mm in diameter for slabs 240 mm thick or more.

4.1.2 Expansion Joints

The primary function of an expansion joint is to provide space for the expansion of the slab, thereby preventing the development of compressive stresses which may cause the slab to buckle. In contrast to contraction joints, complete separation between the two adjacent concrete bays is required and a compressible material is used to fill the void. Expansion joints are also contraction joints. Load transfer between bays is provided by dowels.

Transverse expansion joints are used at the junction between CRCP and other types of pavement or structures and sometimes at regular intervals in JUCP and JRCP.

The construction of this type of joint is relatively costly and the joints require relatively high levels of maintenance. If not well-maintained and not functioning properly, they tend to stay closed after expansion of the slab. This induces excessive opening of the adjacent contraction joints and can become a cause of failure. Their use is consequently avoided when possible. For example, they are generally not required if the slab is cast during the hottest time of the year.

Expansion joints consist of:

- i) Joint filler board.
- ii) Dowel bars.
- iii) Sealing groove.

The joint filler board and sealing groove must be as specified. The dowel bars should be at 300 mm spacing and 600 mm long. They should be:

- i) 25 mm in diameter for slabs up to 239 mm thick.
- ii) 32 mm in diameter for slabs 240 mm thick or more.

4.1.3 Warping Joints

Warping joints allow a slight relative rotation of the slabs and reduce the stresses due to warping.

Transverse warping joints are used for special cases for example:

- i) As extra joints at manhole positions.
- ii) When unreinforced slabs are placed alongside reinforced slabs.
- iii) When unreinforced slabs are long and narrow or tapered (odd-shaped) between normal joint positions. This is to reduce the length/width ratio of the bays to 2 or less.
- iv) In other similar situations.

Warping joints consist of:

- i) A sawn groove.
- ii) Tie bars.
- iii) A sealing groove.

The sealant must be as specified. The tie bars must be 12 mm in diameter at 300 mm spacing and 1000 mm long.

4.2 Longitudinal Joints

Longitudinal joints are warping joints, allowing a slight relative rotation of the slab and reducing the stresses due to warping. They are required at a spacing that will reduce the combination of thermal warping stresses and loading stresses to a minimum. They also

reduce the risk of longitudinal random cracking and often serve, at the same time, as construction joints.

Differential lateral displacements between adjacent (parallel) bays are prevented by tie bars provided at the mid-depth of the slab. These tie bars also prevent the opening of the cracks and thus load transfer is achieved through aggregate interlock.

Longitudinal joints consist of:

- i) Bottom crack inducer.
- ii) A sawn groove.
- iii) Tie bars.
- iv) A sealing groove.

The sealant must be as specified. The tie bars for all longitudinal joints, except where transverse reinforcement is permitted in lieu, should be 12 mm in diameter at 600 mm spacing and 1000 mm long.

4.3 Construction Joints

Construction joints are required to facilitate construction, especially when concreting is stopped. In JUCP and JRCP they should be combined with other joints.

When dealing with transverse construction joints in CRCP, additional reinforcement must be placed. This can be achieved by providing, for each longitudinal reinforcing bar, an additional 700mm long bar of 20mm diameter centred on the joint as shown in Figure 4.1.

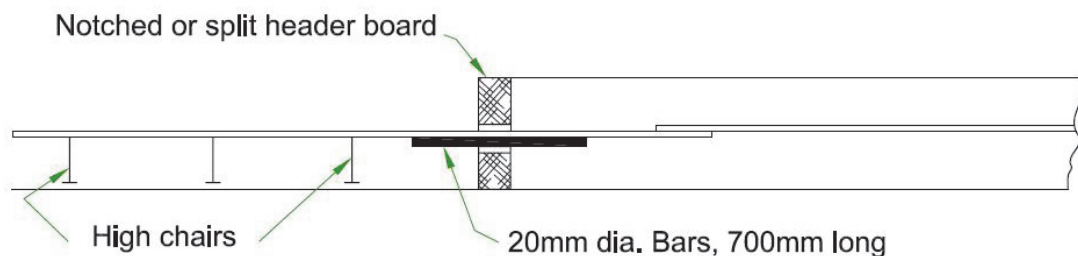

Figure 4-1: Transverse construction joint for CRCP slabs

5 SELECTION OF PAVEMENT TYPE

Concrete pavements are designed for a long life (typically 40 years or more). There is usually very little data available for accurately estimating whole life costs. Furthermore, there is little experience of rigid pavements in Ethiopia. Hence there is no foolproof way of determining the best choice of rigid pavement type for any particular situation. However Figure 5.1 illustrates the principles of a simple selection process that can be used when more experience and performance data have been gained. More details are shown in Figure 6.1.

General guidelines concerning the relative merits of each type are as follows:

- i) JUCP is suitable for all levels of traffic and whenever the risk of subgrade movement is low.
- ii) JRCP is suitable for all levels of traffic and is used when the risk of settlements of the subgrade cannot be neglected.
- iii) CRCP should be considered only for high levels of traffic (>30 million ESAs) and where the low cost of maintenance is paramount; they are particularly suitable where settlement of the sub-soil is an acknowledged risk.
- iv) Less concrete is required if there is more reinforcement.
- v) Less maintenance is required if there are fewer joints.
- vi) Although CRCP potentially provides the best quality pavement overall, it requires an experienced contractor and is the most expensive.

In some cases an over-riding factor can dictate the pavement type. For example, for a very heavily trafficked facility in congested locations, the need to minimize the disruptions and hazard to traffic may dictate the selection of CRCP.

When there is no overriding factor, which is the normal situation, it is standard practice to design typical sections of the road using each of the available options and then to compare them on an economical basis using engineering judgement where data are unavailable.

Unavoidably, there will be situations where only construction costs will determine the type of rigid pavement to build, even though higher maintenance or repair costs may be involved at a later date.

Where circumstances permit, a more realistic economical evaluation has to take into account all expected costs including the initial cost of construction, the cost of subsequent stages or corrective works, anticipated life, maintenance cost and salvage value. Costs to road users during periods of reconstruction or maintenance operations should also be considered. This is particularly important in Ethiopia because alternative or by-pass routes may be very long.

Although pavement structures are based on an initial design period, few are abandoned at the end of this period and continue to serve as part of the future pavement structure. For this reason, the analysis period should be of sufficient duration to include a representative reconstruction of all pavement types.

If the analysis of the above factors does not favour one option above another, a second set of factors can be considered. For example, an evaluation of the skills of the contractors may permit a better appreciation of the risk factor.

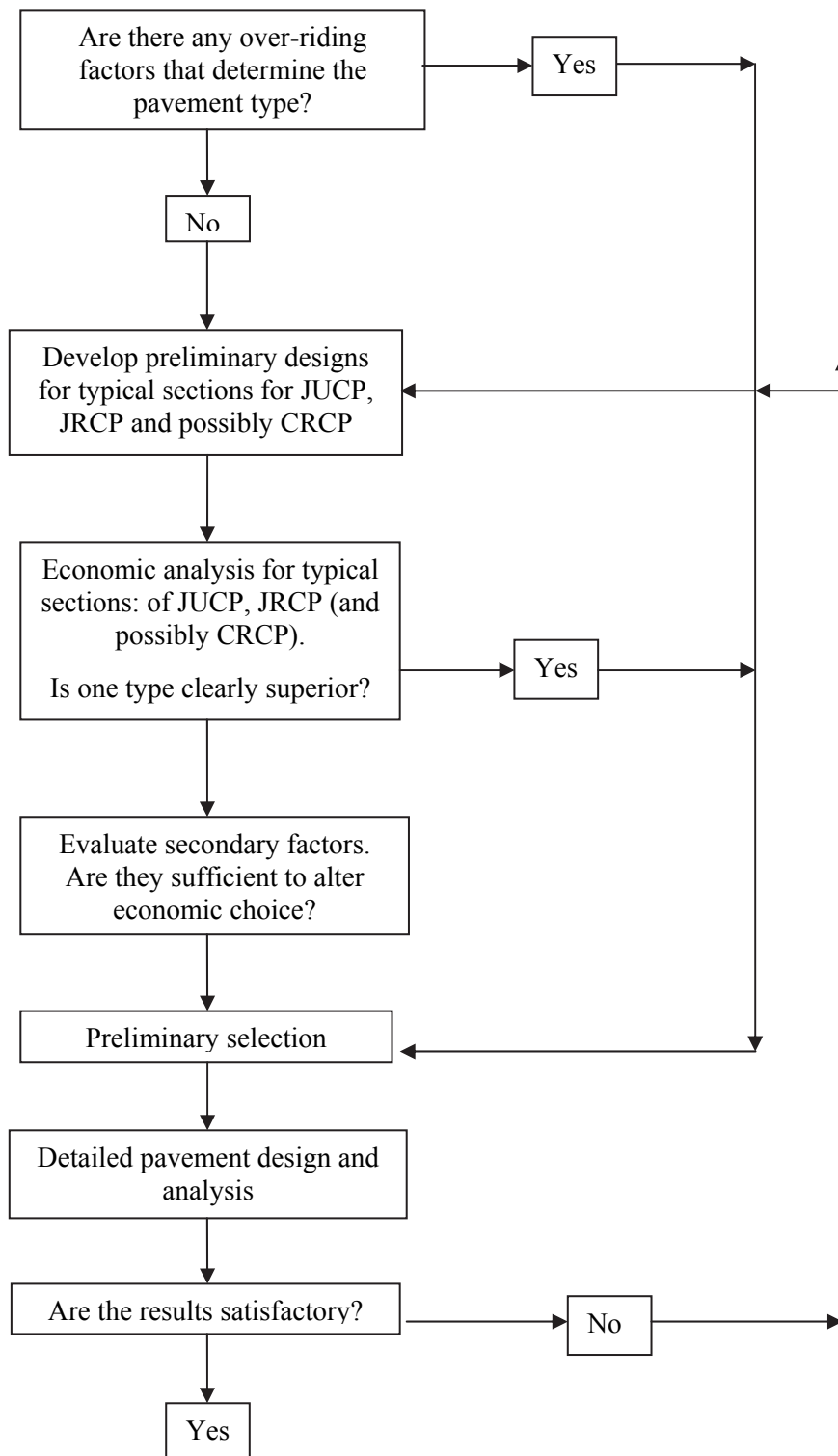

Figure 5.1: Simple selection process for pavement type

6 DESIGNING RIGID PAVEMENTS

6.1 Design Life

A general methodology for rigid pavement design is presented in Figure 6.1.

The durability of concrete is very high and therefore rigid pavements can be designed for periods of up to 60 years, but 40 years is the most common design period. If properly constructed, the pavement will last a long time with a high level of serviceability and low maintenance requirements. However, as with all pavements, the maintenance must not be neglected.

The required slab thickness varies approximately linearly with the logarithm of the cumulative number of ESAs, therefore designing for longer periods requires relatively small additional slab thicknesses and reinforcement.

6.2 Design Traffic Loading

The method of computing cumulative equivalent standard axle loads over the design life of the road is described in ERA's *Pavement Design Manual Volume 1 Flexible Pavements*. The same method is used for rigid pavement but the effective damage law obtained from the AASHO Road Test for rigid pavements is

$$ef = (L/8160)^n \quad (\text{for loads in kg}) \quad \text{Equation 6.1}$$

or
$$ef = (L/80)^n \quad (\text{for loads in kN}) \quad \text{Equation 6.2}$$

Where:

- ef = number of equivalent standard axles (ESAs)
- L = axle load (in kg or kN)
- n = damage exponent ($n = 4.3$)

Table 6.1 shows the values of ESA for different axle loads.

Table 6-1: Equivalency Factors for Rigid Pavements

Wheel load (10³ kg)	Axle load (10³ kg)	Equivalency factor
2.0	4	0.05
2.5	5	0.1
3.0	6	0.3
3.5	7	0.5
4	8	0.9
4.5	9	1.5
5	10	2.4
5.5	11	3.6
6	12	5.2
6.5	13	7.4
7	14	10.2
7.5	15	13.7
8	16	18.0
8.5	17	23.4
9	18	29.9
9.5	19	37.8
10	20	47.1

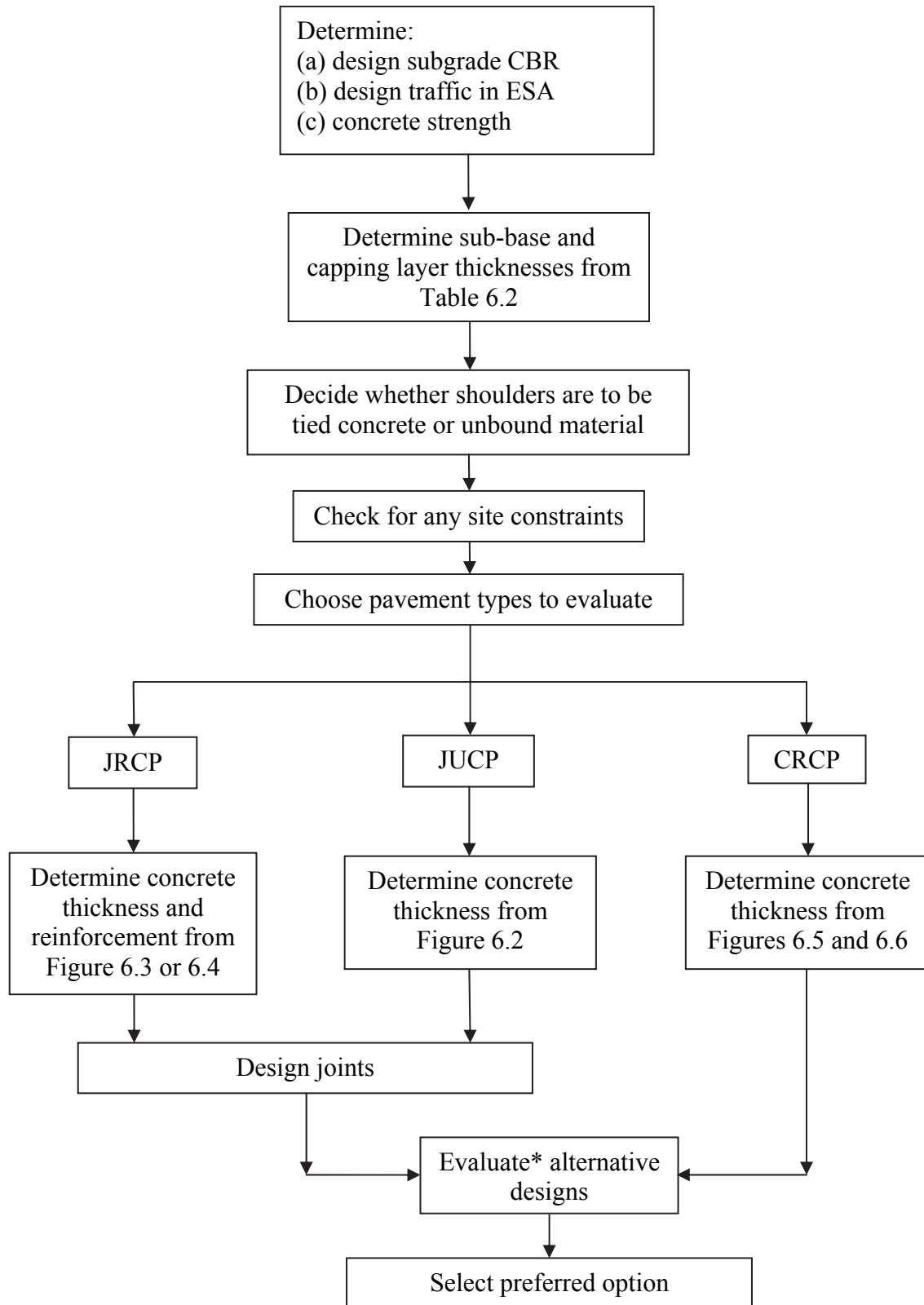

*Note: Project evaluation for long life roads requires numerous assumptions for calculations which, by their nature are not well known. Ultimately, evaluation and choice requires engineering judgement and consensus.

Figure 6-1: Design Process Flow Diagram

6.3 Thickness Design

6.3.1 Capping and Sub-base

A capping layer is required if the design CBR of the subgrade is less than 15%. The required thickness of capping layer and sub-base thickness is shown in Table 6.2.

Table 6-2: Thickness of Sub-base and Capping Layers

Subgrade Class	CBR range %	Sub-base thickness (mm)	Capping layer thickness (mm)
S1	2	200	400
S2	3,4	175	350
S3	5 - 8	150	250
S4	8 - 15	150	200
S5	15 - 30	175	0
S6	>30	0	0

A sub-base layer is required whenever the subgrade material does not comply with the requirement for a sub-base (CBR is less than 30%) but it is usually provided in all cases because the sub-base and capping layers are primarily designed to provide a good working platform for construction activities. This enables construction levels to be more easily achieved within the tolerances required.

Usually the thickness of the sub-base will be 150mm or 175mm, but sometimes the same material is conveniently used as the capping layer.

For very weak subgrades with CBR values less than 3%, the subgrade material needs to be improved by stabilisation or replaced. Soil improvement is described in ERAs *Pavement Design Manual Volume I Flexible Pavements*.

For good performance of the rigid pavement the sub-base material should be very resistant to erosion. To ensure this it should, ideally, be stabilised with cement or lime (Class CS with unconfined compressive strength in the range 0.75-1.5 MPa), especially if the traffic level is high (i.e. the higher classes of road).

The design charts for the concrete pavement thicknesses presented below are based on the assumption that the foundation of sub-base, capping and subgrade has a minimum effective modulus that is achieved by adopting the thicknesses shown in Table 6.2 and with a stabilised sub-base. If the sub-base is not stabilised the thickness of the concrete pavement must be increased as shown in Tables 6.3 and 6.4 for unreinforced and reinforced pavements respectively.

In JUCP and JRCP pavements, a separation membrane (such as a polythene sheet) is required between the sub-base and the concrete slab, mainly to reduce the friction between the slab and the sub-base and thus inhibit the formation of mid-bay cracks. The polythene sheet also reduces the loss of water from the fresh concrete. For CRCP pavements, a

bituminous spray should be used on the sub-base instead of polythene because a high degree of restraint is required.

Table 6-3: Additional Thickness for JUCP with Unstabilised Sub-bases (mm)

	T3	T4	T5	T6	T7	T8	T9	T10	T11
S1	20	25	25	30	35	35	40	45	50
S2	20	25	25	30	35	35	40	45	50
S3	20	25	25	30	35	35	40	45	50
S4	15	15	20	20	25	25	30	30	35
S5	10	10	10	10	15	15	15	20	20
S6	10	10	10	10	15	15	15	20	20

Table 6-4: Additional Thickness for JRCP with Unstabilised Sub-bases (mm)

	T3	T4	T5	T6	T7	T8	T9	T10	T11
S1	15	15	15	20	20	25	25	30	35
S2	15	15	15	20	20	25	25	30	35
S3	15	15	15	20	20	25	25	30	35
S4	10	10	10	15	15	15	20	20	25
S5	5	5	5	10	10	10	10	10	15
S6	5	5	5	10	10	10	10	10	15

6.3.2 Concrete Slab Thickness and Reinforcement

Based on the design traffic volume expressed in Equivalent Standard Axles, the strength of the concrete, the type of rigid pavement, the shoulder design, and the thickness of the pavement are determined as described below.

Jointed Unreinforced Concrete Pavement (JUCP)

The thickness of a JUCP concrete slab is determined from Figure 6.2a and 6.2b, depending on the strength of the concrete. The Figures show the thicknesses required for concrete slabs that have effective support to the edge of the most heavily-trafficked lane (i.e. the right lane) by means of tied shoulders. In the absence of a tied shoulder an additional slab thickness is required as shown in the Figures.

JUCP pavements have no reinforcement. However, the longitudinal and transverse joints are provided with dowels or tie bars depending upon the type of joint. The joint details are described in Chapter 4.

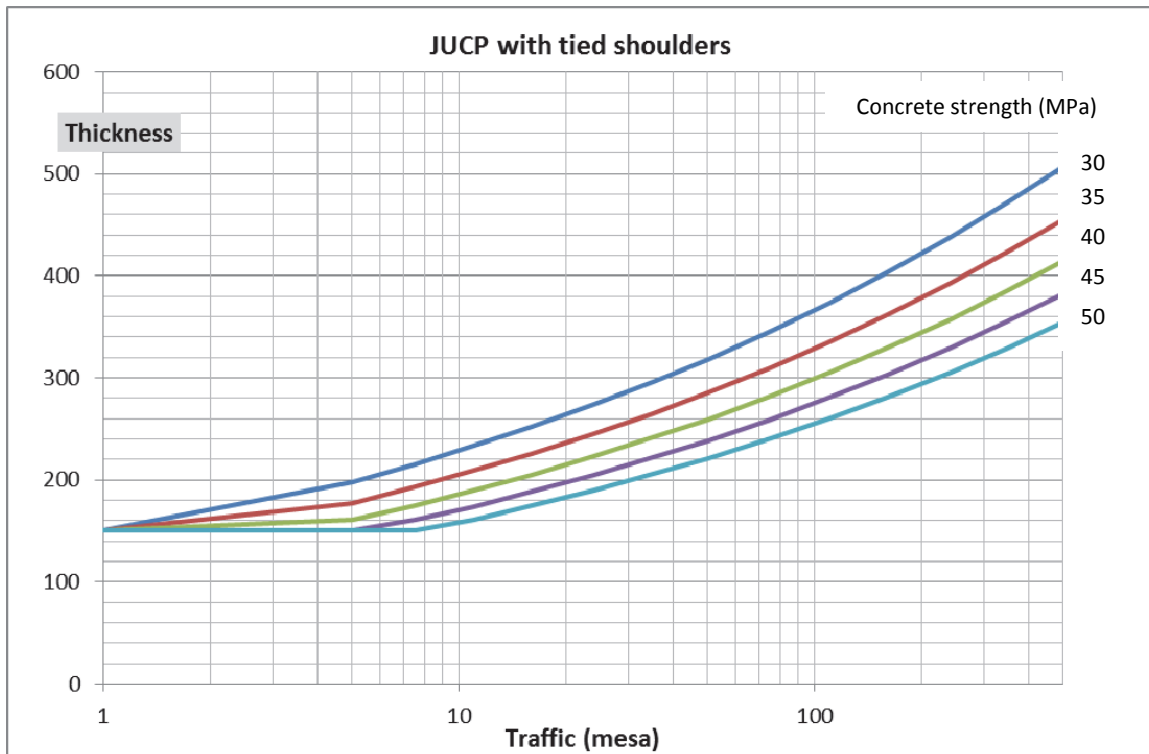

a) Design Thicknesses for JUCP with tied shoulders

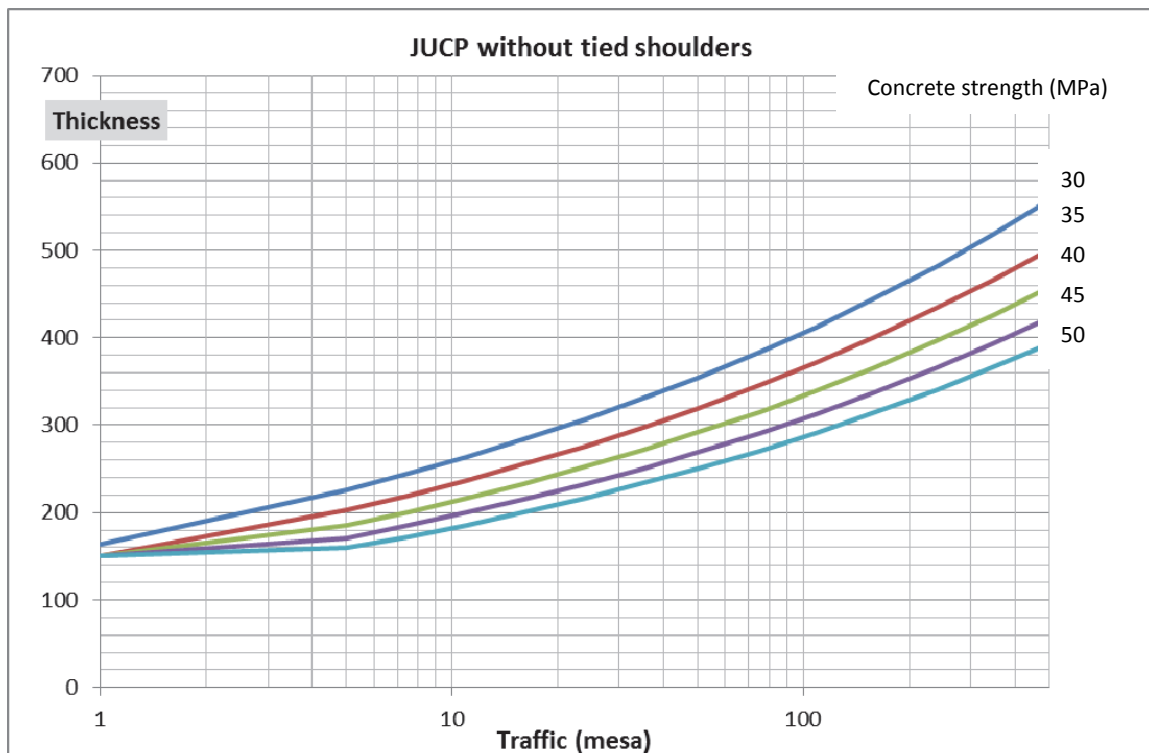

b) Design Thicknesses for JUCP without tied shoulders

Figure 6-2: Design Thicknesses for JUCP with and without tied shoulders

Jointed Reinforced Concrete Pavement (JRCP)

The thickness of JRCP slabs are shown in Figure 6.3 for pavements with tied shoulders and in Figure 6.4 for pavements without tied shoulders for different strengths of concrete. The thickness depends on the amount of reinforcement that is used, as shown in the Figures. Thus there are several alternative combinations of thickness of concrete slab and amount of reinforcement.

In addition to the longitudinal reinforcement, JRCP pavements should be provided with transverse reinforcement consisting of 12 mm diameter steel bars at 600 mm spacing.

The minimum thickness for JUCP and JRCP is 150 mm

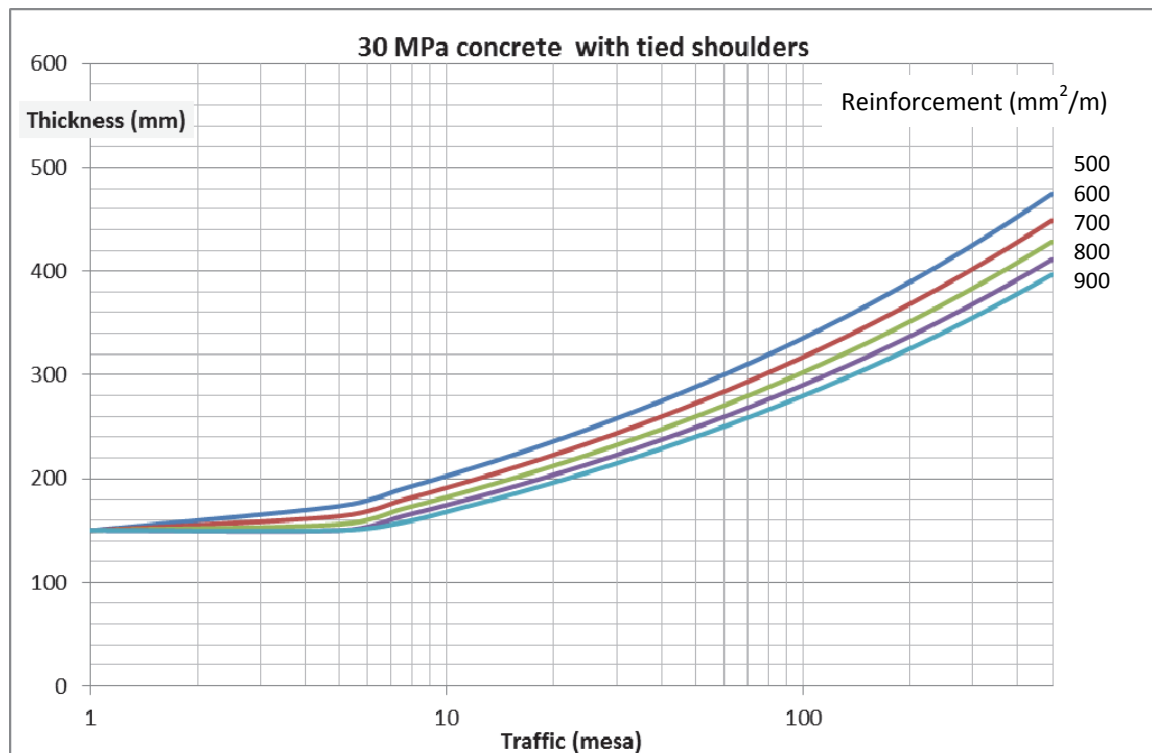

a) Design Thicknesses for JRCP (30 MPa concrete and tied shoulders)

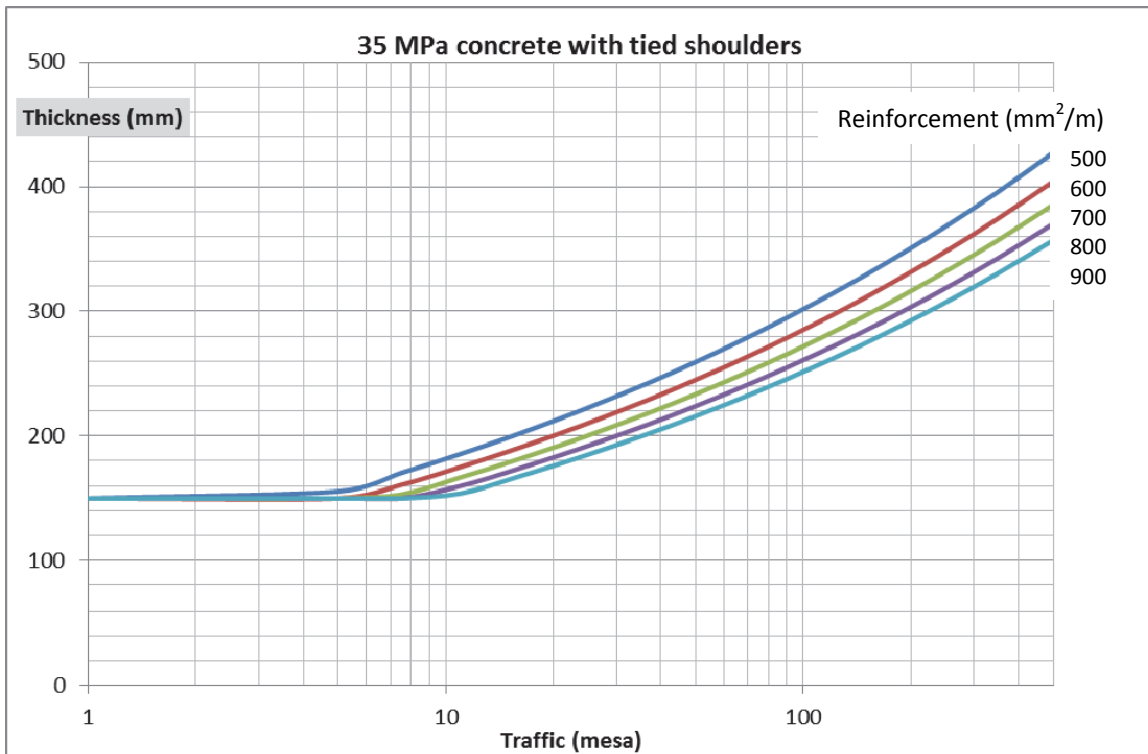

b) Design Thicknesses for JRCP (35 MPa concrete and tied shoulders)

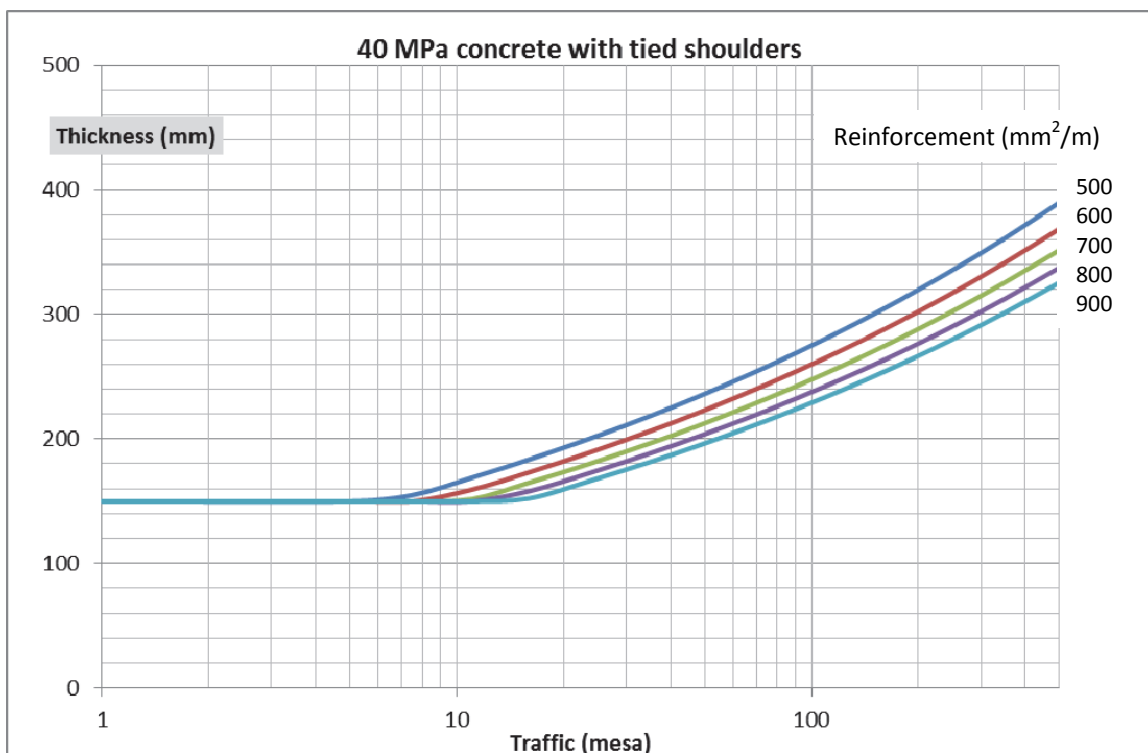

c) Design Thicknesses for JRCP (40 MPa concrete and tied shoulders)

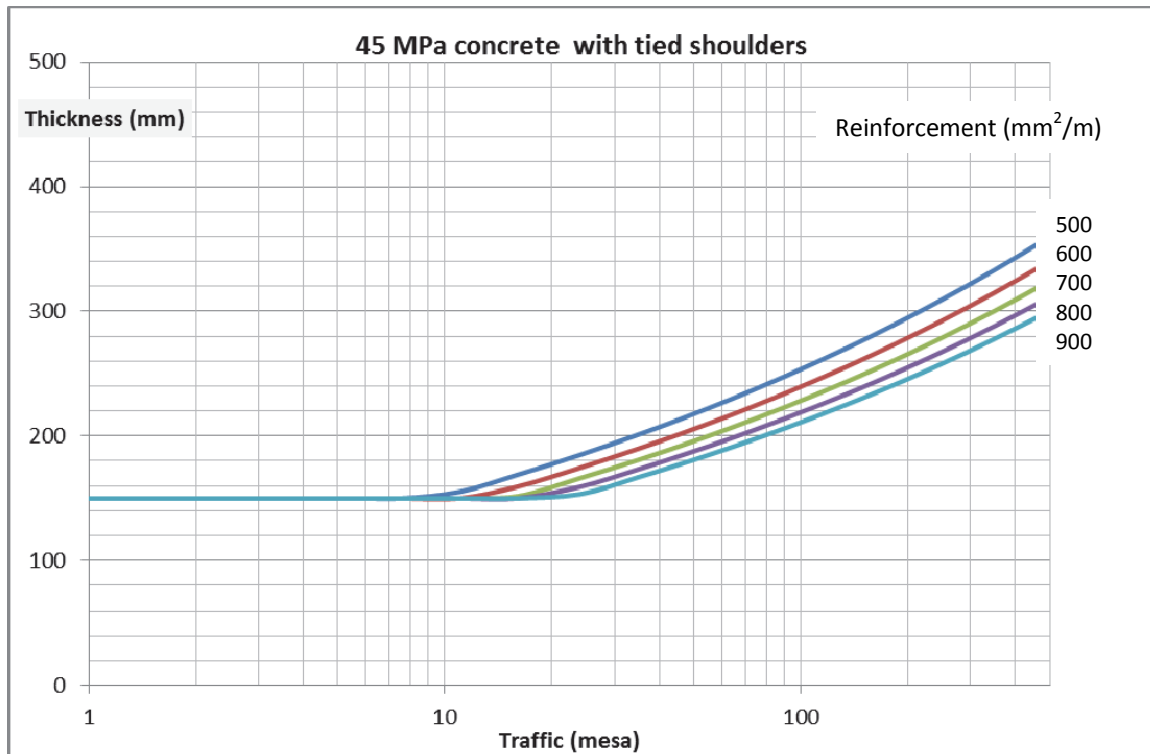

d) Design Thicknesses for JRCP (45 MPa concrete and tied shoulders)

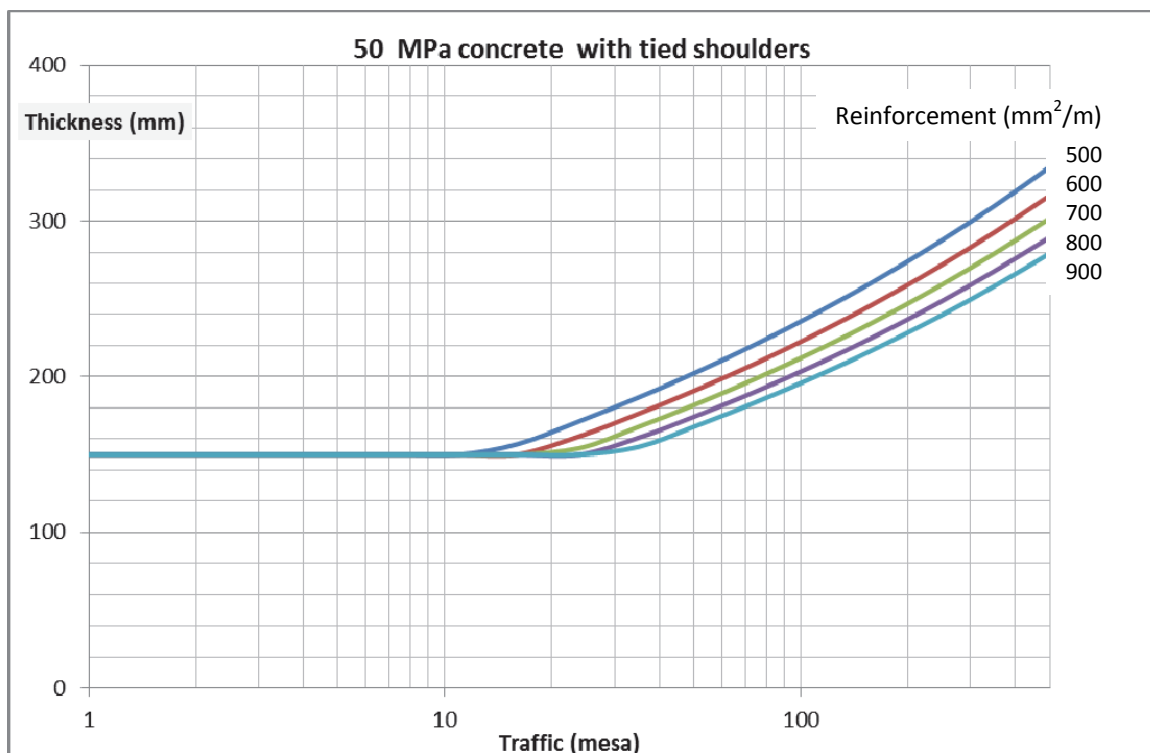

e) Design Thicknesses for JRCP (50 MPa concrete and tied shoulders)

Figure 6-3: Design Thicknesses for JRCP with tied shoulders

(30, 35, 40, 45 and 50 MPa concrete)

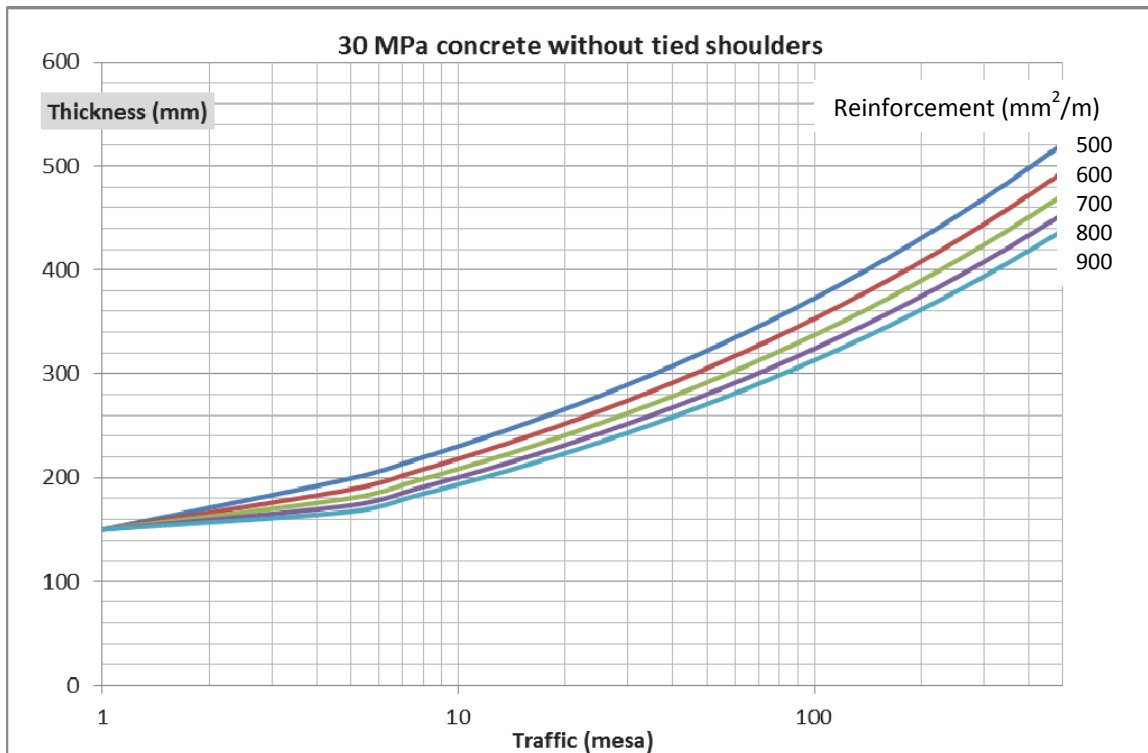

a) Design Thicknesses for JRCPC (30 MPa concrete without tied shoulders)

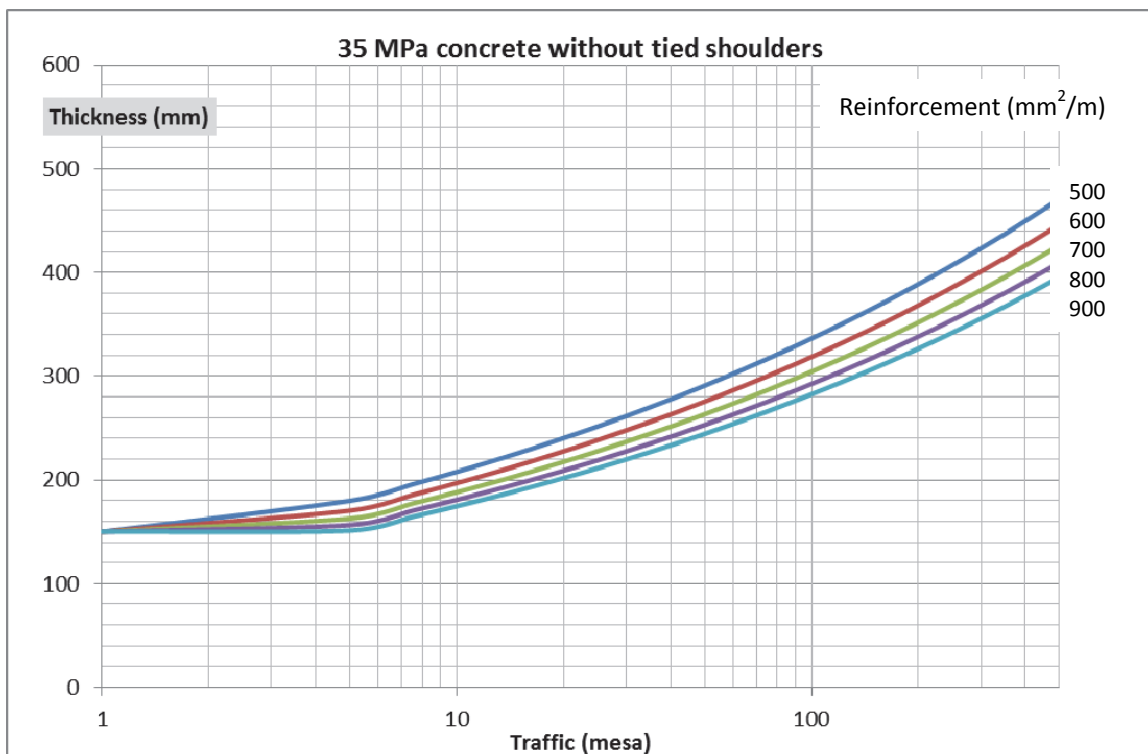

b) Design Thicknesses for JRCPC (35 MPa concrete without tied shoulders)

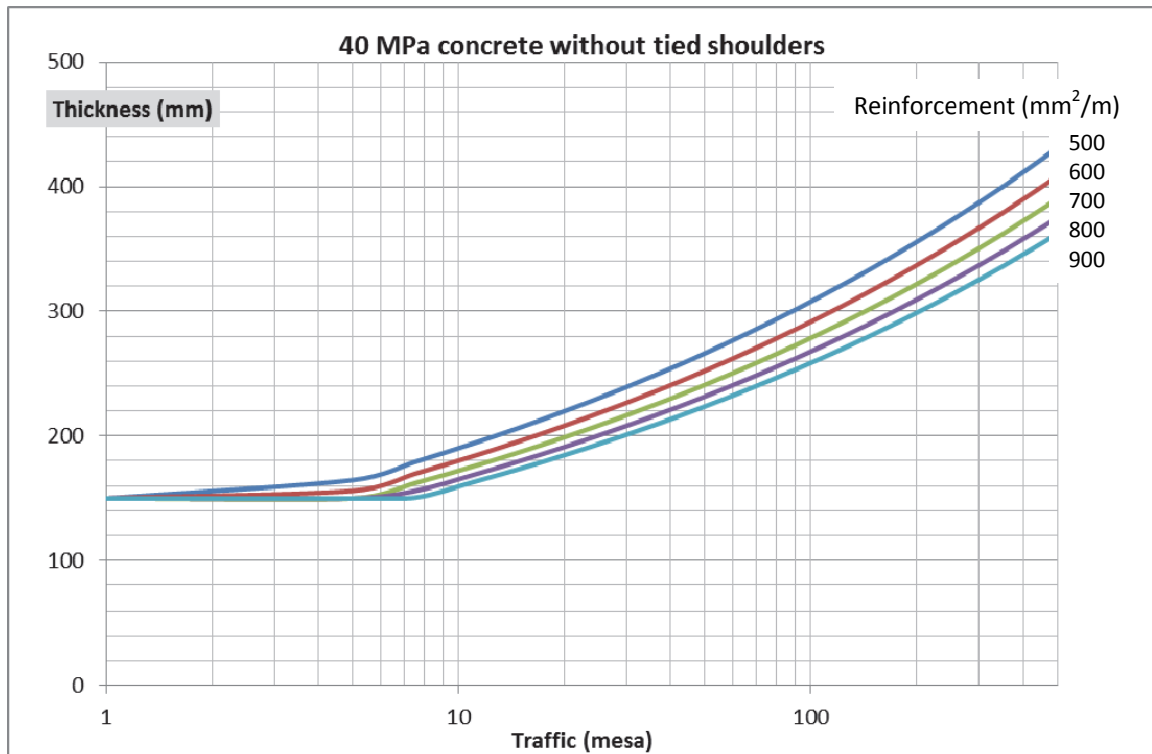

c) Design Thicknesses for JRCP (40 MPa concrete without tied shoulders)

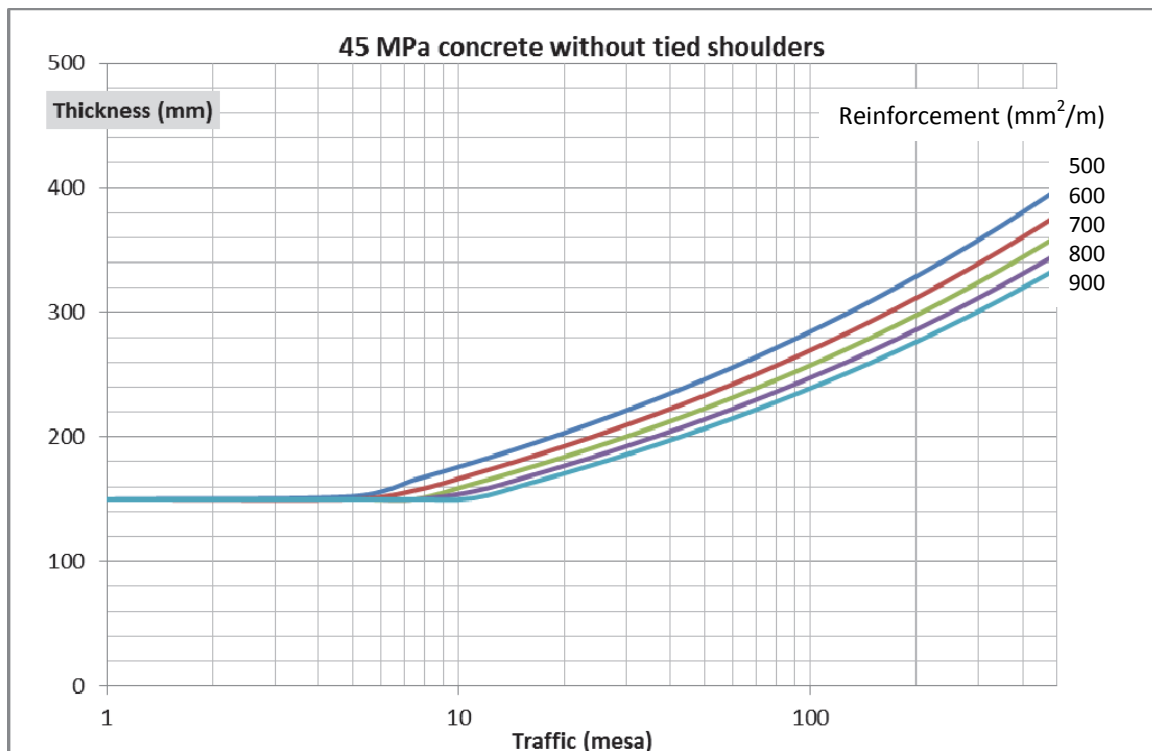

d) Design Thicknesses for JRCP (45 MPa concrete without tied shoulders)

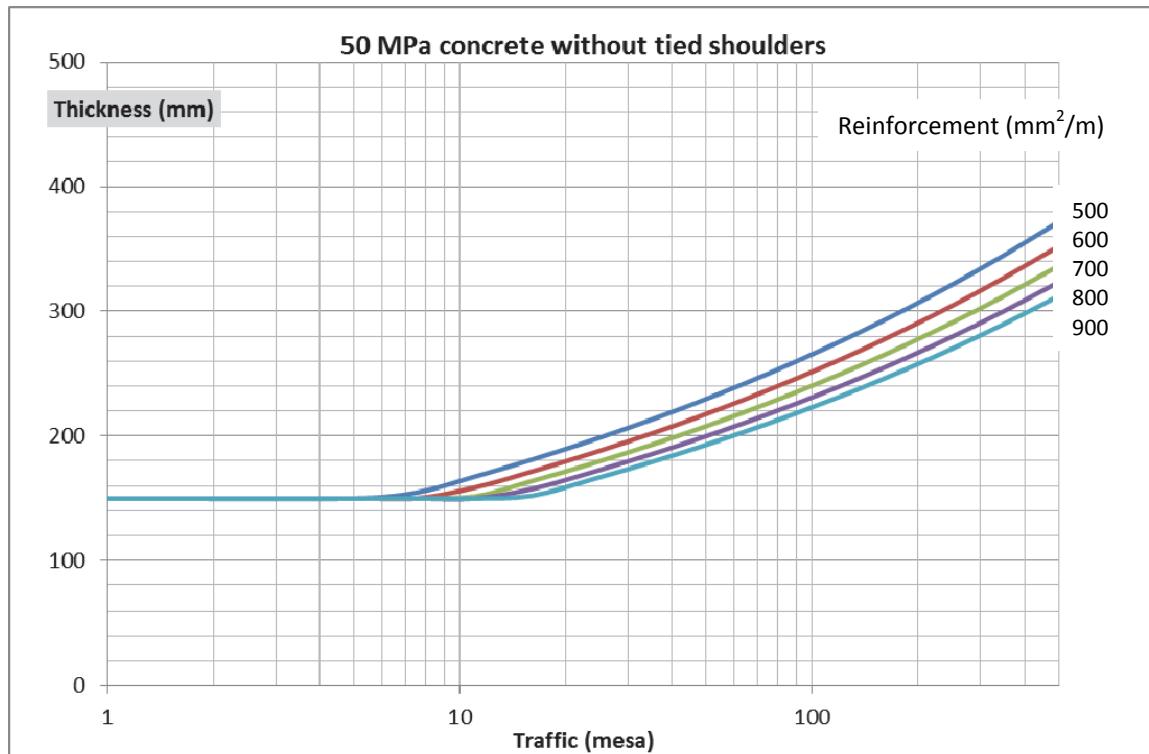

e) Design Thicknesses for JRC (50 MPa concrete without tied shoulders)

Figure 6-4: Design Thicknesses for JRC concrete without tied shoulders
(30, 35, 40, 45 and 50 MPa concrete)

Continuously Reinforced Concrete Pavement (CRCP)

CRCP pavement can better withstand severe stresses induced by differential movements. For a given traffic volume in terms of ESAs, the required thickness of CRCP concrete slab is shown in Figure 6.5.

Longitudinal reinforcement in CRCP pavements should be 0.6% of the concrete slab cross-sectional area, and consist of 16 mm diameter deformed steel bars. Transverse reinforcement should be provided at 600 mm spacing and consist of 12 mm diameter deformed steel bars to prevent the opening of any longitudinal cracks which may form. Transverse reinforcement is also required for ease of construction.

In the absence of effective shoulder support adjacent to the most heavily trafficked lane, an additional slab thickness is required and can be determined from Figure 6.6.

The minimum thickness of concrete for CRCP is 200mm.

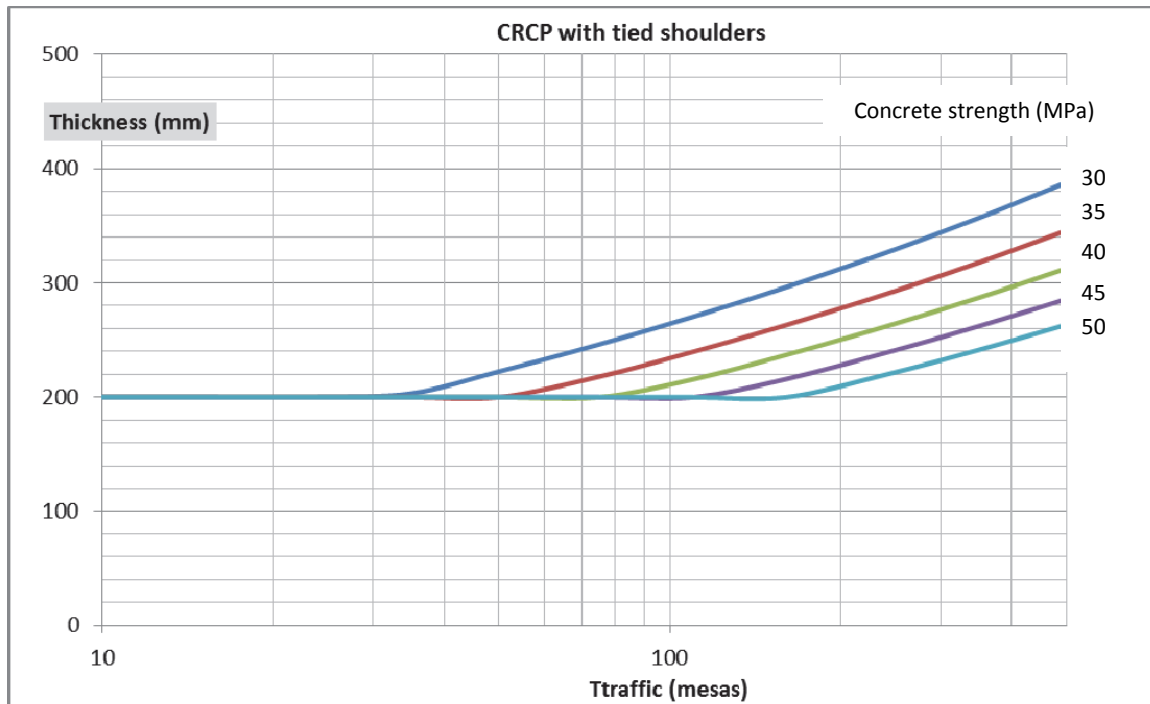

Figure 6-5: Design Thickness for CRCP with tied shoulders

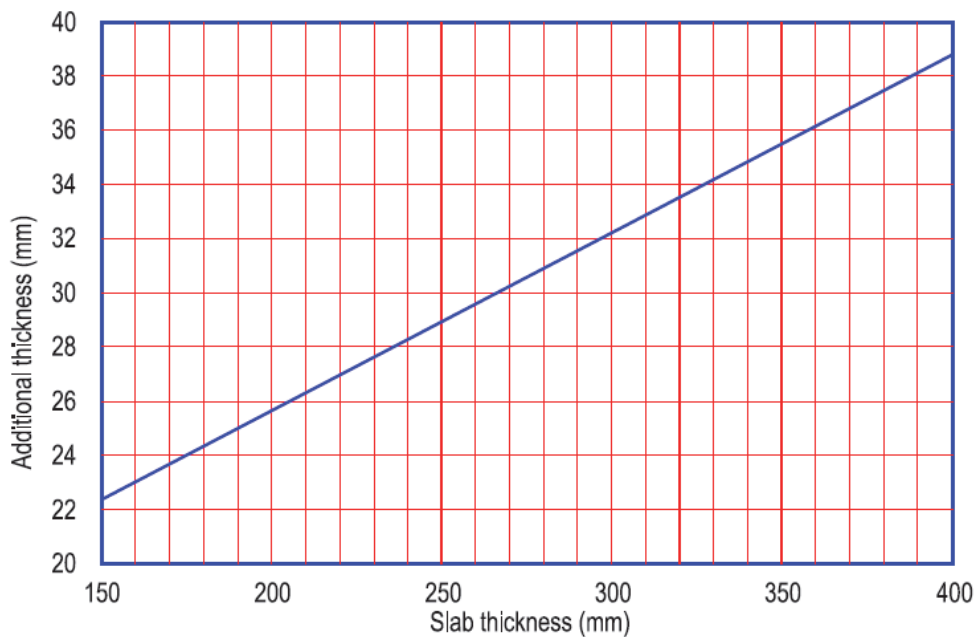

Figure 6-6: Additional Concrete Thickness for CRCP when there is no full lateral support provided by tied shoulders

An example of rigid pavement design is presented in Appendix A.

6.4 Design for Movement

Joints must be designed according to the general considerations of Chapter 4 using Drawings B2 to B8.

The general layout of joints shall account for construction consideration and the following limitations concerning joint spacing and bay dimensions.

6.4.1 Transverse Joint Spacing

The maximum transverse joint spacing for JUCP pavements is 4 metres for slab thicknesses up to 230 mm and 5 metres for slab thicknesses greater than 230 mm.

For JRCP, contraction joints are generally at a standard distance of 25 metres.

Expansion joints are required at the junctions with other pavement types and with structures e.g. bridges. The need for expansion joints elsewhere can be avoided by casting the concrete slab at the hottest period of the year. However, if required, expansion joints should replace every third contraction joint.

6.4.2 Longitudinal Joint Spacing

Longitudinal joints must be placed at the edge of each traffic lane.

6.5 Design Detailing

6.5.1 Bay-layout

The longitudinal and transverse joints (placed as described in Section 6.4) divide the concrete into regular rectangular bays. At specific locations such as crossings, junctions or when man-holes or gulleys are required, different layouts fitting the road geometry must be adopted to prevent the development of warping stresses. The main principles for designing the joint layout at such locations are:

- i) Avoid long, narrow bays with a length/width ratio greater than 2.
- ii) Avoid bays with acute angled corners.
- iii) Avoid bays with re-entrant angles.

The sketches in Figure 6.7 present a possible layout for bays at crossings and junctions illustrating these principles.

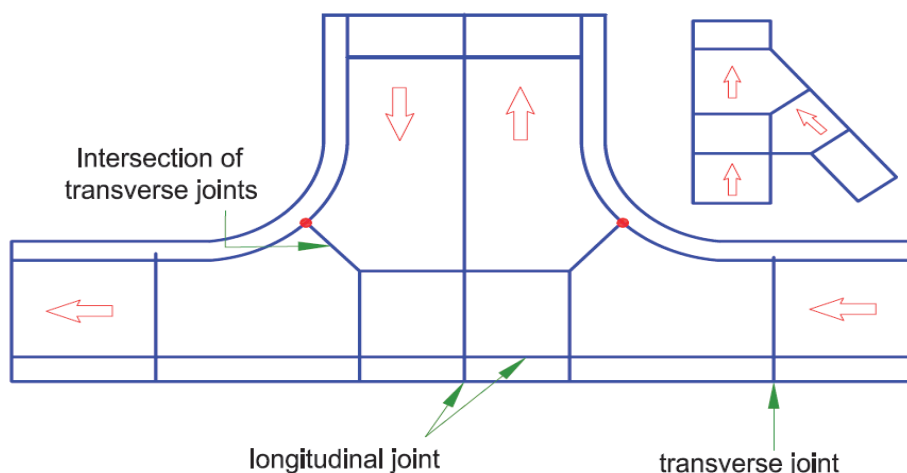

Figure 6-7: Joints layout at junctions and crossings

6.5.2 Gullies and Man-holes

When gullies, man-holes and other ‘in-pavement’ objects are encountered, it is essential to prevent the concrete slab from being supported by the structure. This is achieved by ‘boxing out’ around the object, which means providing an expansion joint without load transfer device.

Since the opening in the slab structure is likely to create a weakened section prone to cracking, it is necessary to locate it at the crossing of normal joints or with additional warping joints as shown in Figure 6.8.

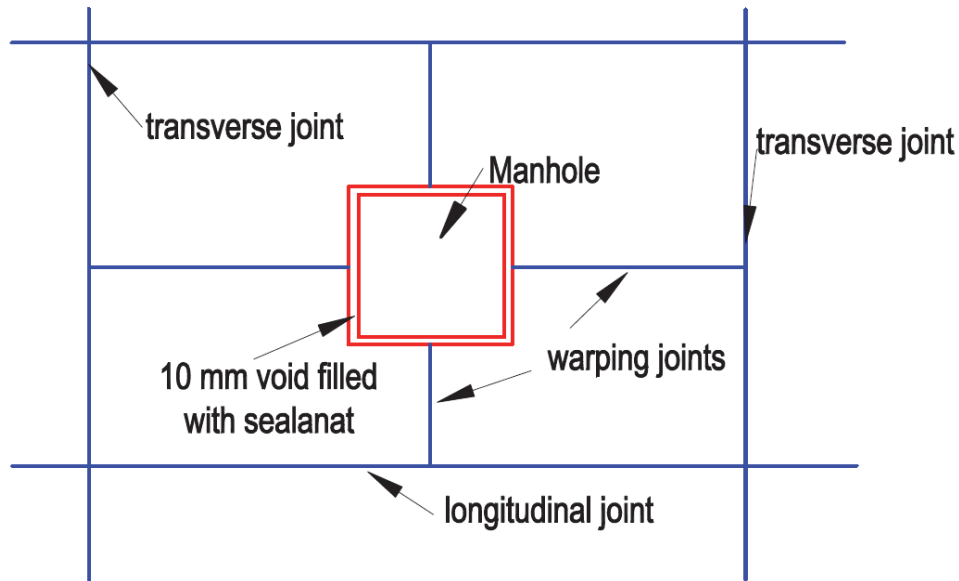

Figure 6-8: Box-out around in-pavement objects – layout of joints

6.5.3 Integral Curbs

Where sidewalks are required, integral curbs should be used and linked to the carriageway slab by a longitudinal joint.

All transverse joints should extend continuously through the pavement and curb.

Figure 6.9 shows typical dimensions and construction provisions for integral curbs.

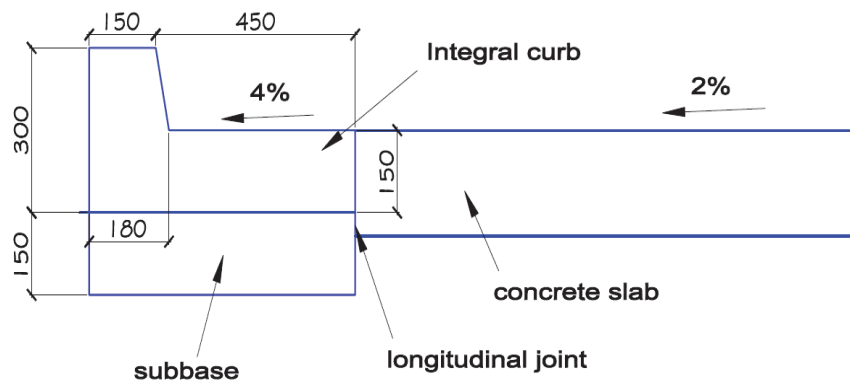

Figure 6-9: Typical Integral Curb

6.5.4 End Anchorage for Continuously Reinforced Pavement Slabs

At the slab ends of a CRCP it is necessary to connect to the adjoining pavement or structure. Anchorage devices are required because the interlayer friction in the concrete pavement is not sufficient to counterbalance the contraction and expansion stresses and this could cause the formation of wide openings. This can be achieved by providing a succession of reinforced concrete lugs which anchor the slab in the soil. The lugs are typically about 1 m deep and cover the entire width of the slab. They are placed every 5 metres over the last 30 metres of the continuous reinforced pavement. The design details are shown in drawing B6 in Appendix B.

7 REFERENCES

Ethiopian Mapping Authority (1988). *National Atlas of Ethiopia.*

Ethiopian Roads Authority (2000). *Pavement Design Manual, Volume 1, Flexible Pavements.*

Transport Research Laboratory (1993). *Road Building in the Tropics.* State-of-the- Art Review, No. 9. TRL., Crowthorne, UK.

American Association of State Highway and Transportation Officials (1993). *AASHTO Guide for Design of Pavement Structures.*

The Department of Transport, London (1997). *Design Manual for Roads and Bridges.*

Highways Agency, UK (1998). *Manual of Contract Documents for Highway Works, Vol. 1: Specification for Highway Works.*

Highways Agency, UK (1998). *Manual of Contract Documents for Highway Works, Vol. 2: Notes for Guidance on the Specification for Highway Works.*

Highways Agency, UK (1998). *Manual of Contract Documents for Highway Works, Vol. 3: Highway Construction Details.*

Mayhew, H C and H M Harding (1987). *Thickness design of concrete roads.* Research Report 87. TRRL, Crowthorne, UK.

APPENDIX A: SUB-BASE AND CAPPING LAYER REQUIREMENTS

The requirements for sub-base and capping layers are essentially the same as for flexible pavements described in ERA's *Pavement Design Manual Volume I Flexible Pavements*. The appropriate sections from that manual are repeated here for convenience.

A1 Sub-Bases (GS)

The sub-base is an important load spreading layer in the completed pavement. It enables traffic stresses to be reduced to acceptable levels in the subgrade. It acts as a working platform for the construction of the upper pavement layers and it acts as a separation layer between subgrade and base course. Under special circumstances, it may also act as a filter or as a drainage layer. In wet climatic conditions, the most stringent requirements are dictated by the need to support construction traffic and paving equipment. In these circumstances, the sub-base material needs to be more tightly specified. In dry climatic conditions, in areas of good drainage, and where the road surface remains well sealed, unsaturated moisture conditions prevail and sub-base specifications may be relaxed. The selection of sub-base materials will therefore depend on the design function of the layer and the anticipated moisture regime, both in service and at construction.

A1.1 Bearing Capacity

A minimum CBR of 30 per cent is required at the highest anticipated moisture content when compacted to the specified field density, usually a minimum of 95 per cent of the maximum dry density achieved in the ASTM Test Method D 1557 (Heavy Compaction). Under conditions of good drainage and when the water table is not near the ground surface (see Chapter 3) the field moisture content under a sealed pavement will be equal to or less than the optimum moisture content in the ASTM Test Method D 698 (Light Compaction). In such conditions, the sub-base material should be tested in the laboratory in an unsaturated state. Except in arid areas (Category 3 in Chapter 3), if the base course allows water to drain into the lower layers, as may occur with unsealed shoulders and under conditions of poor surface maintenance where the base course is pervious (see Section 3.1), saturation of the sub-base is likely. In these circumstances, the bearing capacity should be determined on samples soaked in water for a period of four days. The test should be conducted on samples prepared at the density and moisture content likely to be achieved in the field. In order to achieve the required bearing capacity, and for uniform support to be provided to the upper pavement, limits on soil plasticity and particle size distribution may be required. Materials which meet the recommendations of Tables 6.5 and 6.6 will usually be found to have adequate bearing capacity.

A1.2 Use as a Construction Platform

In many circumstances the requirements of a sub-base are governed by its ability to support construction traffic without excessive deformation or ravelling. A high quality sub-base is therefore required where loading or climatic conditions during construction are severe. Suitable material should possess properties similar to those of a good surfacing material for unpaved roads. The material should be well graded and have a plasticity index at the lower end of the appropriate range for an ideal unpaved road wearing course under the prevailing climatic conditions. These considerations form the basis of the criteria given in Table A1. Material meeting the requirements for severe conditions will usually be of higher quality than the standard sub-base (GS). If materials meeting these requirements are

unavailable, trafficking trials should be conducted to determine the performance of alternative materials under typical site conditions.

In the construction of low-volume roads local experience is often invaluable and a wider range of materials may often be found to be acceptable.

Table A1: Typical Particle Size Distribution for Sub-bases (GS)

Test Sieve (mm)	Percentage by mass of total aggregate passing test sieve (%)
50	100
37.5	80 – 100
20	60 – 100
5	30 – 100
1.18	17 – 75
0.3	9 – 50
0.075	5 – 25

A1.3 Sub-Base as a Filter or Separating Layer

This may be required to protect a drainage layer from blockage by a finer material or to prevent migration of fines and the mixing of two layers. The two functions are similar except that for use as a filter the material needs to be capable of allowing drainage to take place and therefore the amount of material passing the 0.075 mm sieve must be restricted. The following criteria should be used to evaluate a sub-base as a separating or filter layer:

- a) The ratio $\frac{D15 \text{ (coarse layer)}}{D85 \text{ (fine layer)}}$ should be less than 5

where D15 is the sieve size through which 15% by weight of the material passes and D85 is the sieve size through which 85% passes.

- b) The ratio $\frac{D50 \text{ (coarse layer)}}{D50 \text{ (fine layer)}}$ should be less than 25

For a filter to possess the required drainage characteristics a further requirement is:

- c) The ratio $\frac{D15 \text{ (coarse layer)}}{D15 \text{ (fine layer)}}$ should lie between 5 and 40

These criteria may be applied to the materials at both the base course/sub-base and the sub-base/subgrade interfaces.

A2 Selected Subgrade Materials and Capping Layers (GC)

These materials are often required to provide sufficient cover on weak subgrades. They are used in the lower pavement layers as a substitute for a thick sub-base to reduce costs. A cost comparison should be conducted to assess their cost effectiveness.

In some of the design charts, substitution of part of the sub-base with GC quality material is allowed as mentioned in the footnotes to the charts. The substitution ratio is 1.3:1 so, for example, 50mm of sub-base can be replaced with 65mm of GC, provided that the rules in the footnotes are followed. Similarly, a layer of GC material on top of a weak subgrade effectively increases the subgrade class as illustrated in the design charts.

The requirements are less strict than for sub-bases. A minimum CBR of 15 per cent is specified at the highest anticipated moisture content measured on samples compacted in the laboratory at the specified field density. This density is usually specified as a minimum of 95 per cent of the maximum dry density in the ASTM Test Method D 1557 (Heavy Compaction). In estimating the likely soil moisture conditions, the designer should take into account the functions of the overlying sub-base layer and its expected moisture condition and the moisture conditions in the subgrade. If either of these layers is likely to be saturated during the life of the road, then the selected layer should also be assessed in this state. Recommended gradings or plasticity criteria are not given for these materials. However, it is desirable to select reasonably homogeneous materials since this may enhance overall pavement behaviour. The selection of materials which show the least change in bearing capacity from dry to wet is also beneficial.

APPENDIX B: RIGID PAVEMENT DESIGN - DESIGN EXAMPLE

Design of Rigid Pavement for the following data:

- | | |
|--|------------------|
| a) Design period: | 40 years |
| b) Cumulative number of ESAs over the design period (given): | 40×10^6 |
| c) CBR of subgrade material: | 8% |
| d) Width of paved carriageway: | 7.3 m |

Step 1 Check for Capping Layer

Since the CBR value is less than 15%, a capping layer is required.

Referring to Table 6.1, the required thickness of the capping layer for a subgrade CBR of 8% is 200 mm

Step 2 Sub-base

The thickness of the required sub-base layer (Paragraph 6.3.1) is 150 mm.

Step 3 Pavement Slab

From Figure 6.3, for a design traffic of 40×10^6 ESAs and a longitudinal reinforcement of $500 \text{ mm}^2/\text{m}$, the thickness of pavement slab required is 200 mm.

Step 4 Joints

From paragraph 6, the maximum transverse joint spacing is 25 m (JRCP). Since the thickness of concrete slab is 200 mm (< 239 mm), the dowel bars shall be 20 mm in diameter at 300 mm spacing, 400 mm long. Expansion joints are not provided but it is preferable to cast the concrete slab during the hottest period of the year.

One longitudinal joint is placed in the middle of the carriageway, between the two lanes (3.65m each). The tie bars for this slab (< 239 mm in thickness) shall be 12 mm in diameter at 600 mm spacing, 1000 mm long.

Step 5 Final Design

The pavement cross-section is shown below.

- Longitudinal reinforcement: $500 \text{ mm}^2/\text{m}$
- Transverse joint spacing: 25 m
- Longitudinal joint spacing: 3.65 m
- Dowels for transverse joints: 20 mm diameter @ 3000 mm c/c, 400 mm long
- Tie bars for longitudinal joints: 12 mm diameter @ 600 mm c/c, 1000 mm long

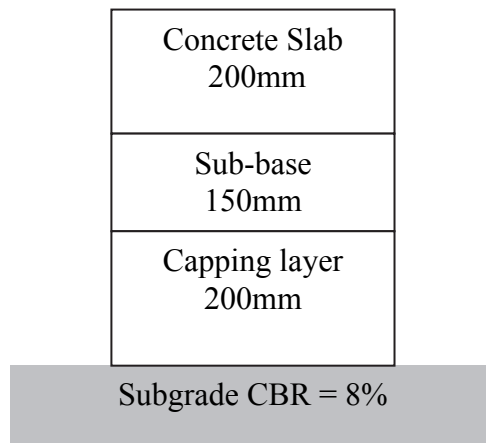

Figure B1: Rigid Pavement Cross-Section

APPENDIX C: TYPICAL DETAILS

Typical detail drawings for rigid pavements are shown in Figures C-1 to C-6 for the three types of concrete pavements, transverse joint details, longitudinal joint details and end anchorages for CRCP.

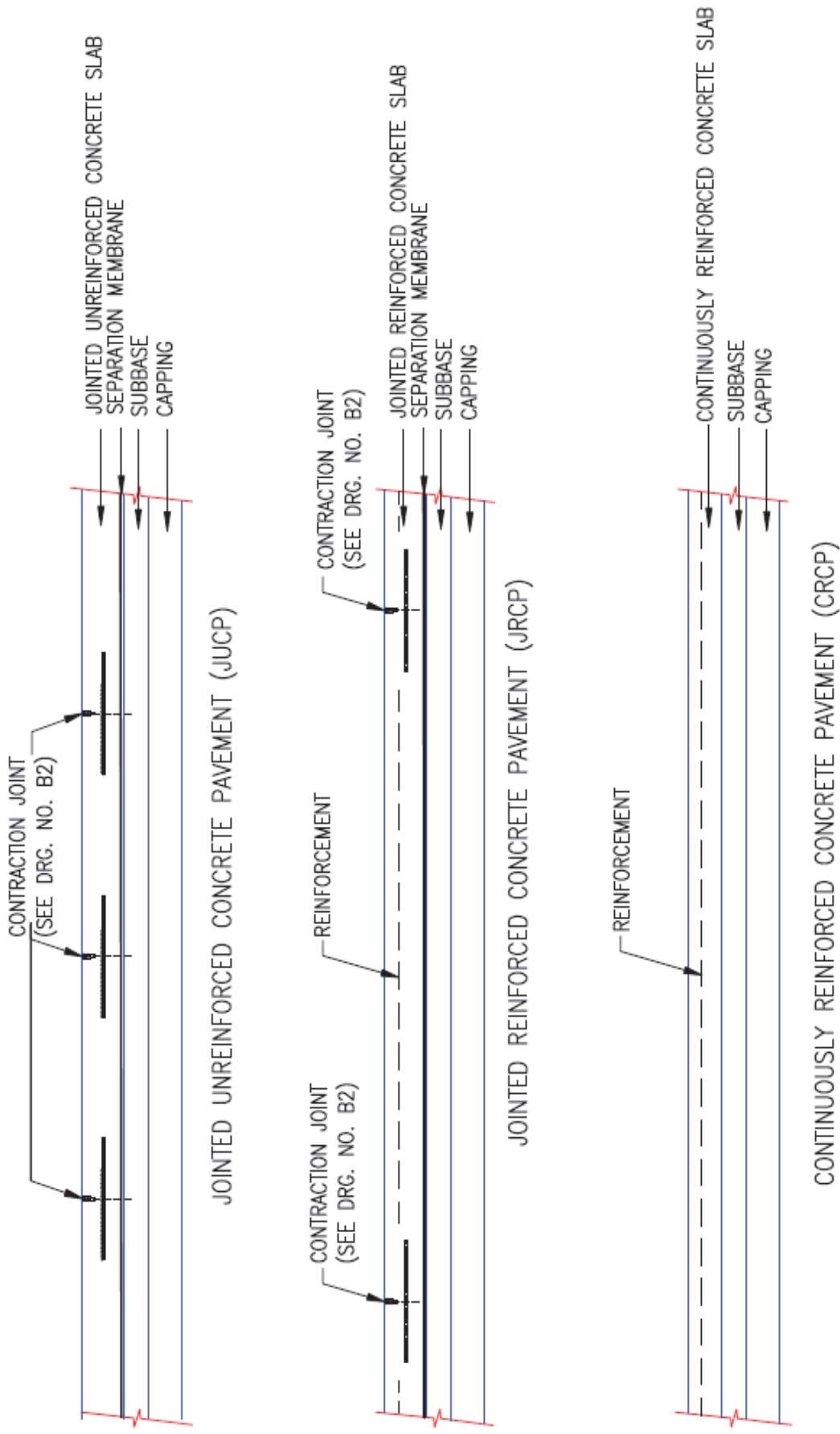
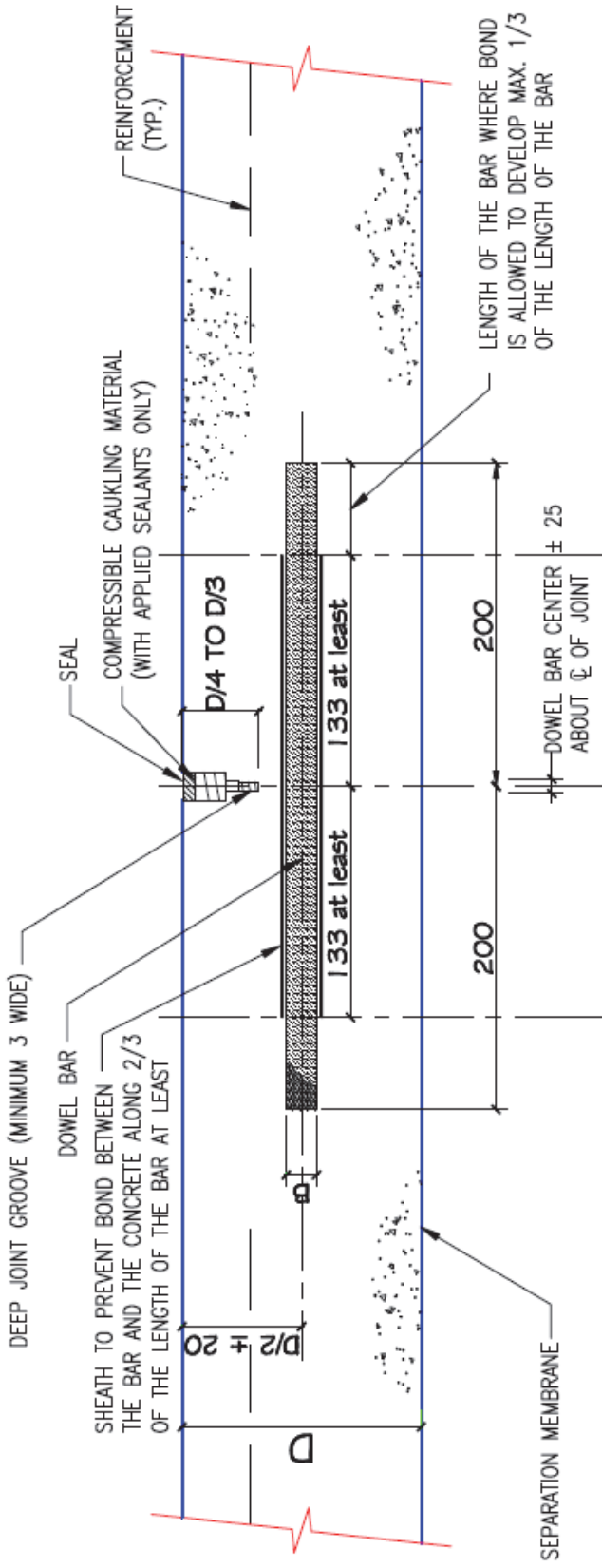

Figure C-1: Types of Rigid Pavements Longitudinal Sections



CONTRACTION JOINT – WITH SAWN GROOVE

NOTES:

1. ALL DIMENSIONS ARE IN MILLIMETERS.
2. THE DOWEL BARS SHALL BE PLACED AT 300 CENTERS. THIS SPACING SHALL BE VARIED WHERE NECESSARY SO THAT NO DOWEL BAR IS WITHIN 150 OF THE EDGE OF THE SLAB OR LONGITUDINAL JOINT.

DIAM. OF DOWEL	
SLAB THICKNESS DIMENSION D	DIMENSION B
150 TO 239	20
239 AND OVER	25

Figure C-2: Contraction Joints

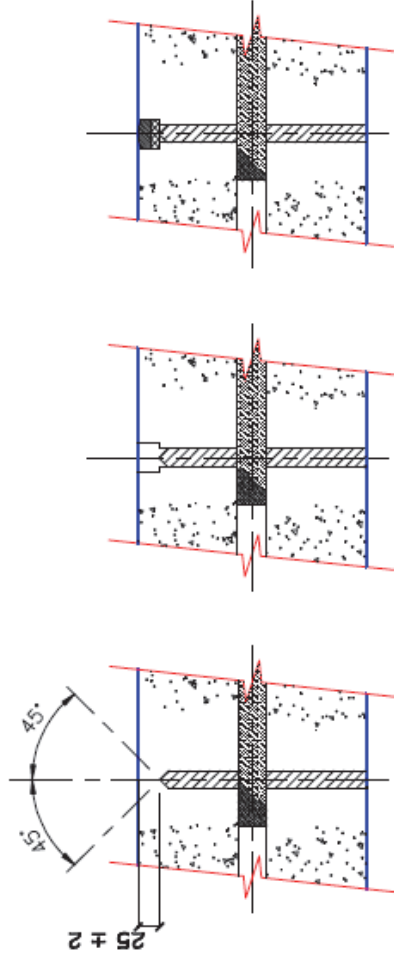
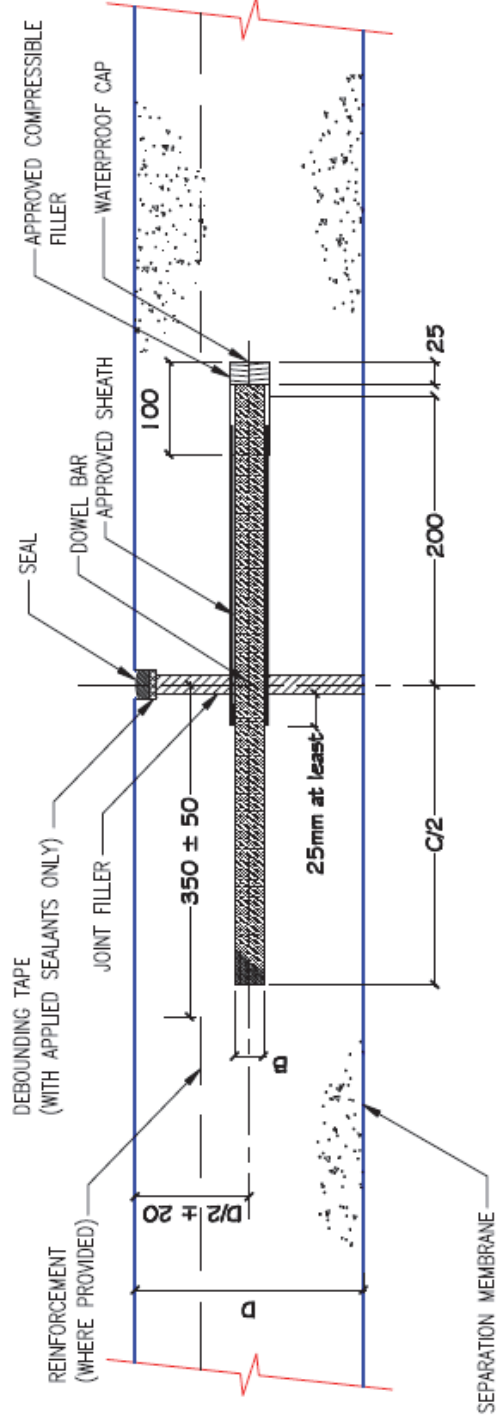

1. JOINT BEFORE SAWING 2. JOINT AFTER SAWING 3. JOINT SEALED
SAWN SEALING GROOVE DETAIL

DOWEL BAR		
SLAB THICKNESS DIMENSION D	DIMENSION B	DIMENSION C
150 TO 239	20	600
239 AND OVER	25	600

- NOTES:
1. ALL DIMENSIONS ARE IN MILLIMETERS.
 2. THE DOWEL BARS SHALL BE PLACED AT 300 CENTERS. THIS SPACING SHALL BE VARIED WHERE NECESSARY SO THAT NO DOWEL BAR IS WITHIN 150 OF THE SLAB EDGE OR A JOINT PARALLEL TO THE BARS.

Figure C-3: Expansion Joints JUCP and JRCP Concrete Slabs

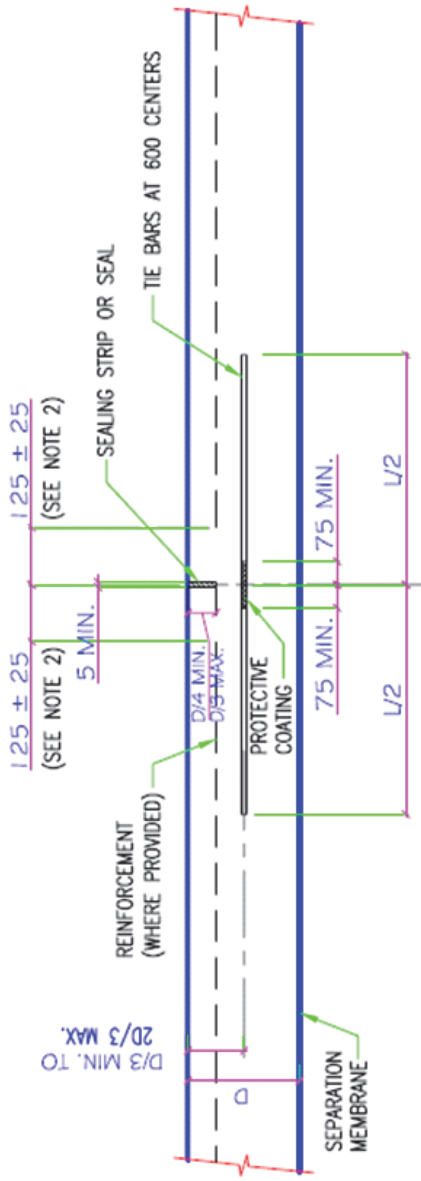

TYPE 1

LONGITUDINAL CONSTRUCTION JOINT BETWEEN TWO SEPARATELY CONSTRUCTED JUCP OR JRCP SLABS

NOTES:

1. ALL DIMENSIONS ARE IN MILLIMETERS.
2. REINFORCEMENT TO TERMINATE AT THESE POINTS.

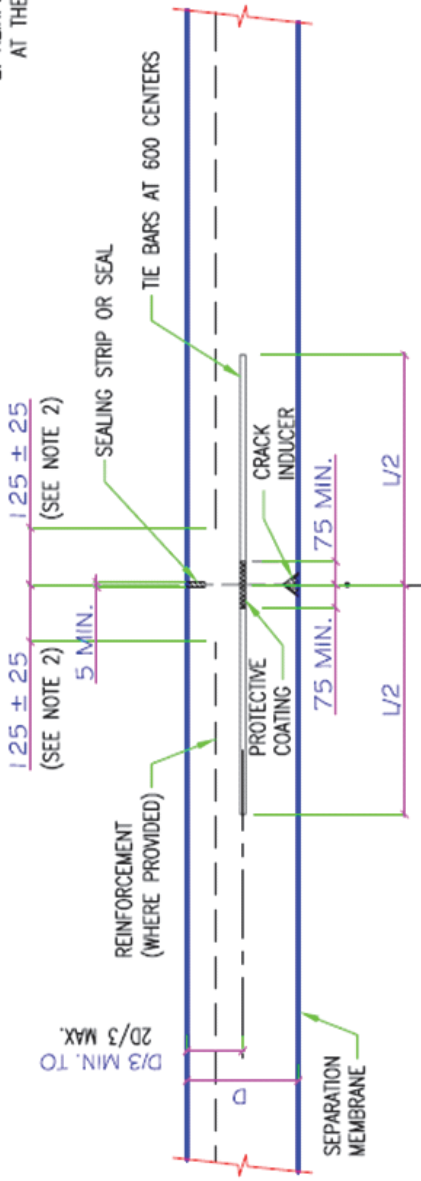

TYPE 2

WE FORMED LONGITUDINAL JOINT FOR SLABS MORE THAN ONE LANE WIDTH CONSTRUCTED IN ONE OPERATION

TIE BARS	
DIAMETER	LENGTH L
12	750

Figure C-4: Longitudinal Joints for JUCP or JRCP Slabs

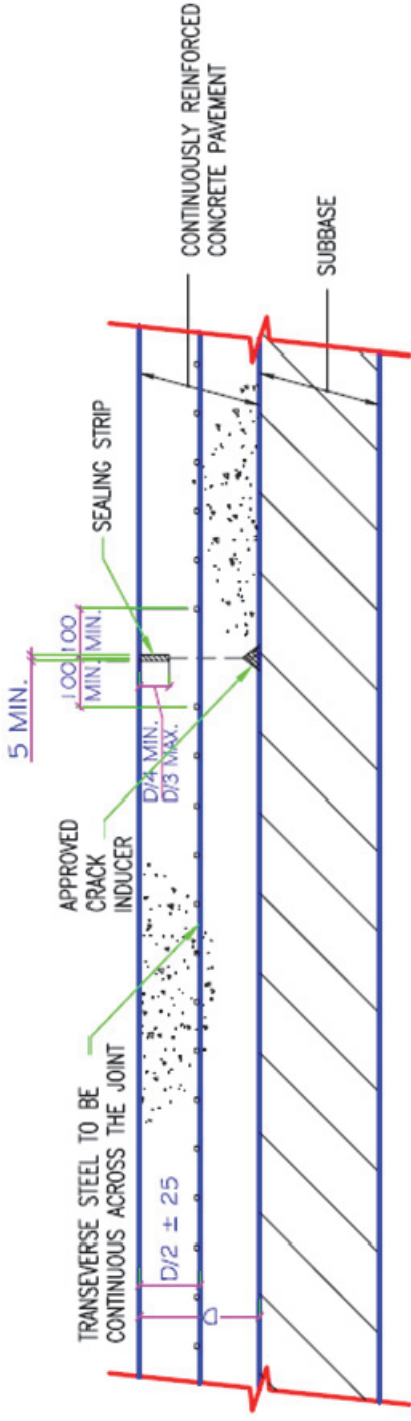

WET – FORMED LONGITUDINAL JOINT GROOVE FOR CRCP
(CONSTRUCTED IN MORE THAN ONE LANE WIDTH IN ONE OPERATION)

NOTES:

1. ALL DIMENSIONS ARE IN MILLIMETERS UNLESS OTHERWISE STATED.
2. THE BARS SHALL BE PLACED EQUALLY ABOUT THE JOINT ± 50 AT THE SAME SPACING AS AND ADJACENT TO THE TRANSVERSE REINFORCEMENT. PROTECTIVE COATING TO BE APPLIED TO THE CENTER 150 (MIN.) OF THE BARS.

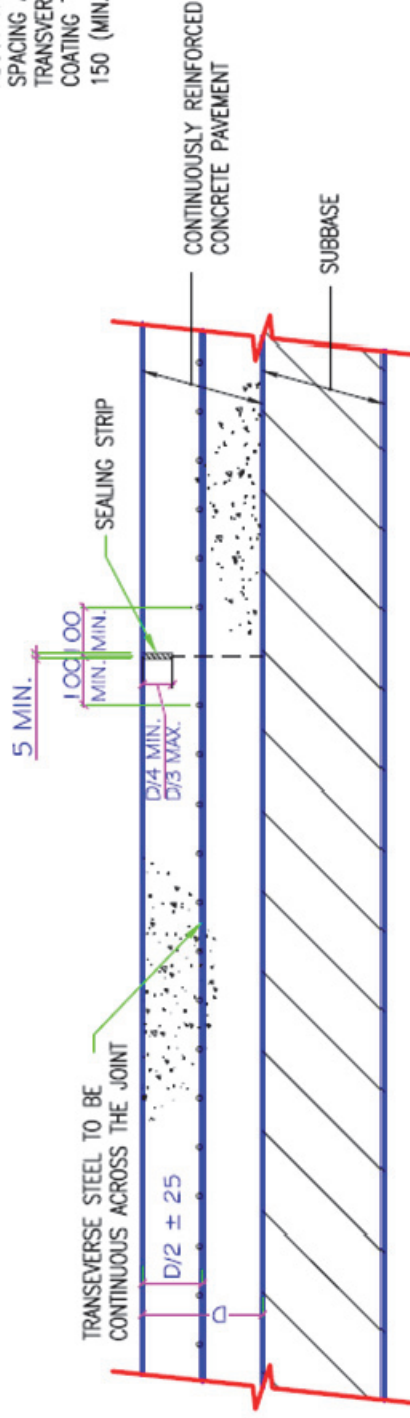

SAWN LONGITUDINAL JOINT FOR CRCP
(CONSTRUCTED IN MORE THAN ONE LANE WIDTH IN ONE OPERATION)

TIE BARS	
DIAMETER	LENGTH L
12	750
16	600
20	500

Figure C-5: Longitudinal Joints Continuously Reinforced Concrete Slabs

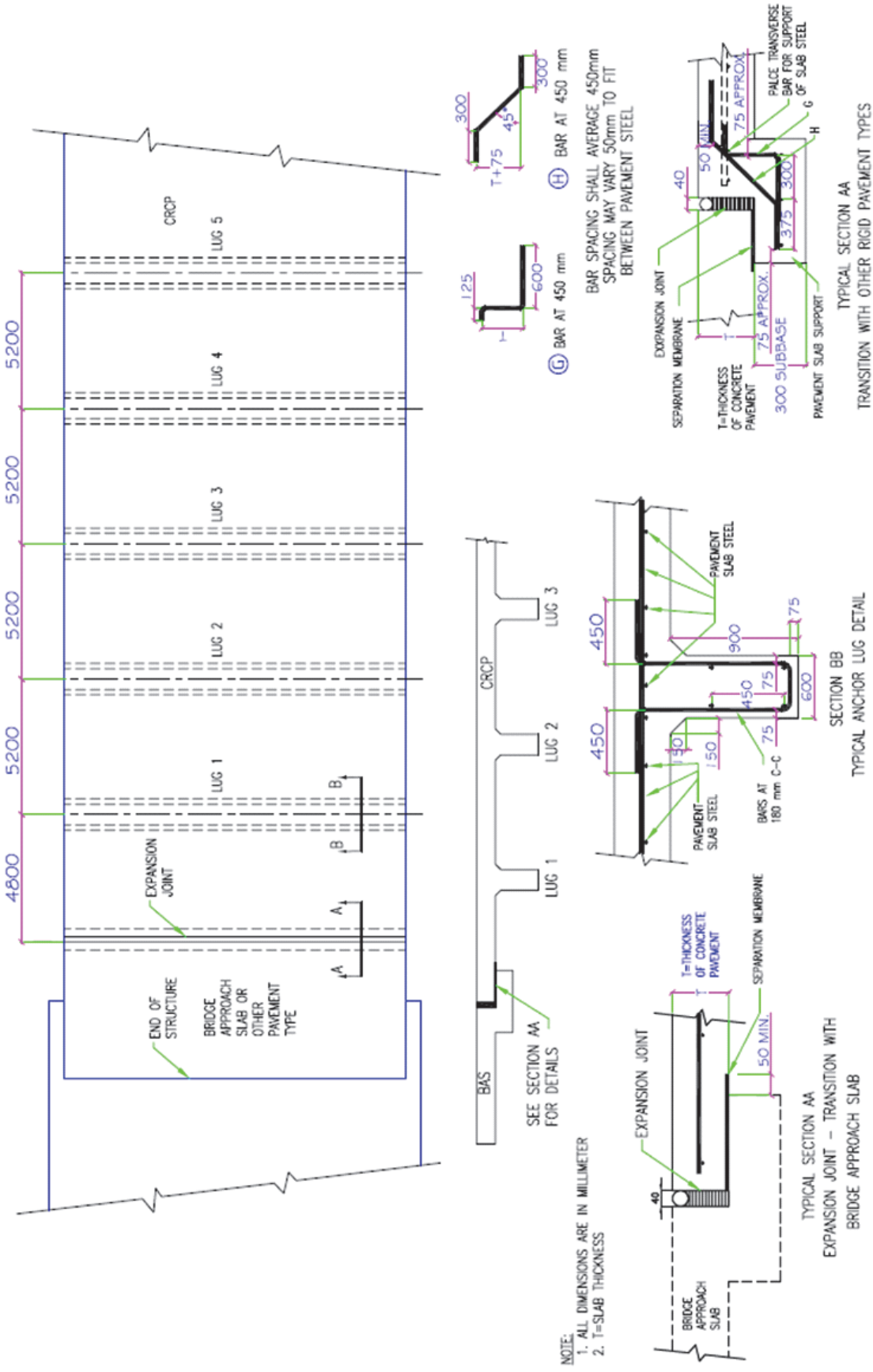

Figure C-6: End Anchorage for CRCP Slabs